

# JVC

# SERVICE MANUAL

## COLOUR VIDEO MONITOR

BASIC CHASSIS

S1

### TM-H1700G/E

### TM-H1700G/U

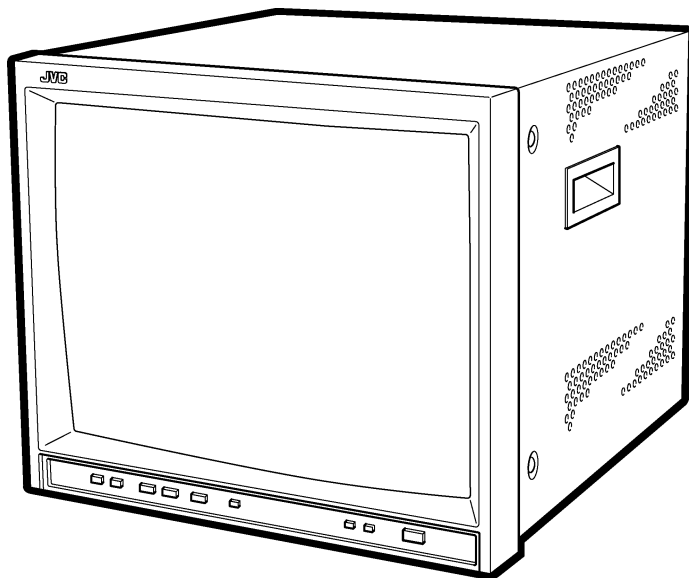

## CONTENTS

- SPECIFICATIONS ..... 2
- ★ OPERATING INSTRUCTIONS (APPENDIX) ..... 1-1
- SAFETY PRECAUTIONS ..... 3
- SPECIFIC SERVICE INSTRUCTIONS ..... 6
- SERVICE ADJUSTMENTS ..... 12
- ★ STANDARD CIRCUIT DIAGRAM (APPENDIX) ..... 2-1
- PARTS LIST ..... 39

# SPECIFICATIONS

Item	Content	
<b>Dimension (W × H × D)</b>	395mm × 334mm × 418.1mm / 15-5/8" × 13-1/4" × 16-1/2"	
<b>Mass</b>	19.6kg / 43.2lbs	
<b>Colour system</b>	PAL / NTSC 3.58	
<b>Picture tube</b>	17inch square type 41cm / 16-3/16" measured diagonally in-line gun, trio-dot type, dot pitch 0.27mm	
<b>Effective screen size</b>	327.5mm × 246.2mm (W × H) / 407.1mm (Diagonal) 12-7/8" × 9-5/8" (W × H) / 16-1/32" (Diagonal)	
<b>Scanning frequency</b>	(H)15.734 kHz (NTSC) 15.625 kHz (PAL) (V)59.94 Hz (NTSC) 50Hz (PAL)	
<b>Horizontal resolution</b>	750TV line or more	
<b>Colour Temperature</b>	6500K ; x = 0.313, y = 0.329 9300k ; x = 0.283, y = 0.297	
<b>Power requirements</b>	230V AC, 50/60 Hz [TM-H1700G/E] 120V AC, 50/60 Hz [TM-H1700G/U]	
<b>High Voltage</b>	25.0kV~27.0kv [at zero beam current]	
<b>Power consumption</b>	0.7A [TM-H1700G/E] 1.1A [TM-H1700G/U]	
<b>Input / output terminal</b>		
<b>Input A</b>	<b>Composite video signal</b>	BNC connector × 2, 1Vp-p, 75Ω, negative sync 1 bridge-connected output possible with automatic termination
	<b>Audio signal</b>	Monaural, RCA pin × 1, 500mV(rms) High-impedance, 1-bridge-connected output possible
<b>Input B</b>	<b>Composite video signal</b>	BNC connector × 2, 1Vp-p, 75Ω, negative sync 1 bridge-connected output possible with automatic termination
	<b>Y/C separate signal</b>	Mini Din 4pin × 2, 1 bridge-connected output possible with automatic termination Y : 1.0Vp-p, 75Ω C : NTSC burst 0.286Vp-p, 75Ω PAL burst 0.3Vp-p, 75Ω
	<b>Audio signal</b>	Monaural, RCA pin × 1, 500mV(rms) High-impedance, 1-bridge-connected output possible
<b>Remote control input</b>	D-sub 15pin Make or TRG can switched in MENU	
<b>Audio power output</b>	1W (Monaural)	
<b>Speaker</b>	8cm round × 1, impedance 8Ω	
<b>Operation temperature</b>	0~40°C (32~104° F)	
<b>Operation humidity</b>	20~80% (non-condensing)	

*Design & specifications are subject to change without notice.*

# SAFETY PRECAUTIONS

**For District of power requirement is 120V AC (Mainly North America)**

- The design of this product contains special hardware, many circuits and components specially for safety purposes. For continued protection, no changes should be made to the original design unless authorized in writing by the manufacturer. Replacement parts must be identical to those used in the original circuits. Service should be performed by qualified personnel only.
- Alterations of the design or circuitry of the products should not be made. Any design alterations or additions will void the manufacturer's warranty and will further relieve the manufacturer of responsibility for personal injury or property damage resulting therefrom.
- Many electrical and mechanical parts in the products have special safety-related characteristics. These characteristics are often not evident from visual inspection nor can the protection afforded by them necessarily be obtained by using replacement components rated for higher voltage, wattage, etc. Replacement parts which have these special safety characteristics are identified in the parts list of Service manual. **Electrical components having such features are identified by shading on the schematics and by (Δ) on the parts list in Service manual.** The use of a substitute replacement which does not have the same safety characteristics as the recommended replacement part shown in the parts list of Service manual may cause shock, fire, or other hazards.
- Use isolation transformer when hot chassis.**  
The chassis and any sub-chassis contained in some products are connected to one side of the AC power line. An isolation transformer of adequate capacity should be inserted between the product and the AC power supply point while performing any service on some products when the HOT chassis is exposed.
- Don't short between the LIVE side ground and ISOLATED (NEUTRAL) side ground or EARTH side ground when repairing.**  
Some model's power circuit is partly different in the GND. The difference of the GND is shown by the LIVE : (⊥) side GND, the ISOLATED(NEUTRAL) : (⚡) side GND and EARTH : (⊕) side GND. Don't short between the LIVE side GND and ISOLATED(NEUTRAL) side GND or EARTH side GND and never measure with a measuring apparatus (oscilloscope etc.) the LIVE side GND and ISOLATED(NEUTRAL) side GND or EARTH side GND at the same time.  
If above note will not be kept, a fuse or any parts will be broken.
- If any repair has been made to the chassis, it is recommended that the B1 setting should be checked or adjusted (See ADJUSTMENT OF B1 POWER SUPPLY).
- The high voltage applied to the picture tube must conform with that specified in Service manual. Excessive high voltage can cause an increase in X-Ray emission, arcing and possible component damage, therefore operation under excessive high voltage conditions should be kept to a minimum, or should be prevented. If severe arcing occurs, remove the AC power immediately and determine the cause by visual inspection (incorrect installation, cracked or melted high voltage harness, poor soldering, etc.). To maintain the proper minimum level of soft X-Ray emission, components in the high voltage circuitry including the picture tube must be the exact replacements or alternatives approved by the manufacturer of the complete product.
- Do not check high voltage by drawing an arc. Use a high voltage meter or a high voltage probe with a VTVM. Discharge the picture tube before attempting meter connection, by connecting a clip lead to the ground frame and connecting the other end of the lead through a 10kΩ 2W resistor to the anode button.
- When service is required, observe the original lead dress. Extra precaution should be given to assure correct lead dress in the high voltage circuit area. Where a short circuit has occurred, those components that indicate evidence of overheating should be replaced. Always use the manufacturer's replacement components.

- Isolation Check (Safety for Electrical Shock Hazard)**  
After re-assembling the product, always perform an isolation check on the exposed metal parts of the cabinet (antenna terminals, video/audio input and output terminals, Control knobs, metal cabinet, screwheads, earphone jack, control shafts, etc.) to be sure the product is safe to operate without danger of electrical shock.

- (1) Dielectric Strength Test**  
The isolation between the AC primary circuit and all metal parts exposed to the user, particularly any exposed metal part having a return path to the chassis should withstand a voltage of 1100V AC (r.m.s.) for a period of one second.  
(. . . Withstand a voltage of 1100V AC (r.m.s.) to an appliance rated up to 120V, and 3000V AC (r.m.s.) to an appliance rated 200V or more, for a period of one second.)  
This method of test requires a test equipment not generally found in the service trade.

- (2) Leakage Current Check**  
Plug the AC line cord directly into the AC outlet (do not use a line isolation transformer during this check.). Using a "Leakage Current Tester", measure the leakage current from each exposed metal part of the cabinet, particularly any exposed metal part having a return path to the chassis, to a known good earth ground (water pipe, etc.). Any leakage current must not exceed 0.5mA AC (r.m.s.).  
However, in tropical area, this must not exceed 0.2mA AC (r.m.s.).

**● Alternate Check Method**

Plug the AC line cord directly into the AC outlet (do not use a line isolation transformer during this check.). Use an AC voltmeter having 1000 ohms per volt or more sensitivity in the following manner. Connect a 1500Ω 10W resistor paralleled by a 0.15μF AC-type capacitor between an exposed metal part and a known good earth ground (water pipe, etc.). Measure the AC voltage across the resistor with the AC voltmeter. Move the resistor connection to each exposed metal part, particularly any exposed metal part having a return path to the chassis, and measure the AC voltage across the resistor. Now, reverse the plug in the AC outlet and repeat each measurement. Any voltage measured must not exceed 0.75V AC (r.m.s.). This corresponds to 0.5mA AC (r.m.s.).  
However, in tropical area, this must not exceed 0.3V AC (r.m.s.). This corresponds to 0.2mA AC (r.m.s.).

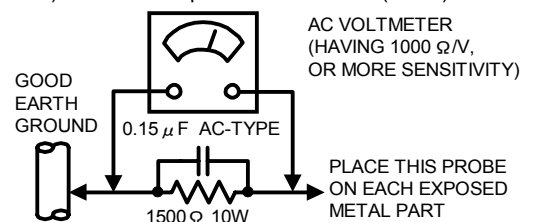

- High voltage hold down circuit check.**  
After repair of the high voltage hold down circuit, this circuit shall be checked to operate correctly.  
See item "How to check the high voltage hold down circuit".

This mark shows a fast operating fuse, the letters indicated below show the rating.

**POWER CORD REPLACEMENT WARNING.**  
Connecting the white line side of power cord to "WHT" character side.

# SAFETY PRECAUTIONS

For District of power requirement is 230V~  
240V AC (Europe, Asia and Oceania)

1. The design of this product contains special hardware, many circuits and components specially for safety purposes. For continued protection, no changes should be made to the original design unless authorized in writing by the manufacturer. Replacement parts must be identical to those used in the original circuits. Service should be performed by qualified personnel only.
2. Alterations of the design or circuitry of the products should not be made. Any design alterations or additions will void the manufacturer's warranty and will further relieve the manufacturer of responsibility for personal injury or property damage resulting therefrom.
3. Many electrical and mechanical parts in the products have special safety-related characteristics. These characteristics are often not evident from visual inspection nor can the protection afforded by them necessarily be obtained by using replacement components rated for higher voltage, wattage, etc. Replacement parts which have these special safety characteristics are identified in the parts list of Service manual. **Electrical components having such features are identified by shading on the schematics and by (Δ) on the parts list in Service manual.** The use of a substitute replacement which does not have the same safety characteristics as the recommended replacement part shown in the parts list of Service manual may cause shock, fire, or other hazards.
4. **Don't short between the LIVE side ground and ISOLATED (NEUTRAL) side ground or EARTH side ground when repairing.**  
Some model's power circuit is partly different in the GND. The difference of the GND is shown by the LIVE : (L) side GND, the ISOLATED(NEUTRAL) : (⌚) side GND and EARTH : (⊕) side GND. Don't short between the LIVE side GND and ISOLATED(NEUTRAL) side GND or EARTH side GND and never measure with a measuring apparatus (oscilloscope etc.) the LIVE side GND and ISOLATED(NEUTRAL) side GND or EARTH side GND at the same time.  
If above note will not be kept, a fuse or any parts will be broken.
5. If any repair has been made to the chassis, it is recommended that the B1 setting should be checked or adjusted (See ADJUSTMENT OF B1 POWER SUPPLY).
6. The high voltage applied to the picture tube must conform with that specified in Service manual. Excessive high voltage can cause an increase in X-Ray emission, arcing and possible component damage, therefore operation under excessive high voltage conditions should be kept to a minimum, or should be prevented. If severe arcing occurs, remove the AC power immediately and determine the cause by visual inspection (incorrect installation, cracked or melted high voltage harness, poor soldering, etc.). To maintain the proper minimum level of soft X-Ray emission, components in the high voltage circuitry including the picture tube must be the exact replacements or alternatives approved by the manufacturer of the complete product.
7. Do not check high voltage by drawing an arc. Use a high voltage meter or a high voltage probe with a VTVM. Discharge the picture tube before attempting meter connection, by connecting a clip lead to the ground frame and connecting the other end of the lead through a 10kΩ 2W resistor to the anode button.
8. When service is required, observe the original lead dress. Extra precaution should be given to assure correct lead dress in the high voltage circuit area. Where a short circuit has occurred, those components that indicate evidence of overheating should be replaced. Always use the manufacturer's replacement components.

9. **Isolation Check (Safety for Electrical Shock Hazard)**  
After re-assembling the product, always perform an isolation check on the exposed metal parts of the cabinet (antenna terminals, video/audio input and output terminals, Control knobs, metal cabinet, screwheads, earphone jack, control shafts, etc.) to be sure the product is safe to operate without danger of electrical shock.
  - (1) **Dielectric Strength Test**  
The isolation between the AC primary circuit and all metal parts exposed to the user, particularly any exposed metal part having a return path to the chassis should withstand a voltage of 3000V AC (r.m.s.) for a period of one second.  
(. . . Withstand a voltage of 1100V AC (r.m.s.) to an appliance rated up to 120V, and 3000V AC (r.m.s.) to an appliance rated 200V or more, for a period of one second.)  
This method of test requires a test equipment not generally found in the service trade.
  - (2) **Leakage Current Check**  
Plug the AC line cord directly into the AC outlet (do not use a line isolation transformer during this check.). Using a "Leakage Current Tester", measure the leakage current from each exposed metal part of the cabinet, particularly any exposed metal part having a return path to the chassis, to a known good earth ground (water pipe, etc.). Any leakage current must not exceed 0.5mA AC (r.m.s.).  
However, in tropical area, this must not exceed 0.2mA AC (r.m.s.).
- **Alternate Check Method**  
Plug the AC line cord directly into the AC outlet (do not use a line isolation transformer during this check.). Use an AC voltmeter having 1000 ohms per volt or more sensitivity in the following manner. Connect a 1500Ω 10W resistor paralleled by a 0.15μF AC-type capacitor between an exposed metal part and a known good earth ground (water pipe, etc.). Measure the AC voltage across the resistor with the AC voltmeter. Move the resistor connection to each exposed metal part, particularly any exposed metal part having a return path to the chassis, and measure the AC voltage across the resistor. Now, reverse the plug in the AC outlet and repeat each measurement. Any voltage measured must not exceed 0.75V AC (r.m.s.). This corresponds to 0.5mA AC (r.m.s.).  
However, in tropical area, this must not exceed 0.3V AC (r.m.s.). This corresponds to 0.2mA AC (r.m.s.).

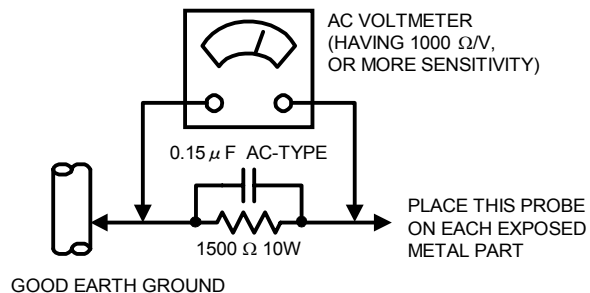

# SAFETY PRECAUTIONS

For UK and Hong Kong

1. The design of this product contains special hardware and many circuits and components specially for safety purposes. For continued protection, no changes should be made to the original design unless authorized in writing by the manufacturer. Replacement parts must be identical to those used in the original circuits. Service should be performed by qualified personnel only.
2. Alterations of the design or circuitry of the product should not be made. Any design alterations or additions will void the manufacturer's warranty and will further relieve the manufacturer of responsibility for personal injury or property damage resulting therefrom.
3. Many electrical and mechanical parts in the product have special safety-related characteristics. These characteristics are often not evident from visual inspection nor can the protection afforded by them necessary be obtained by using replacement components rated for higher voltage, wattage, etc. Replacement parts which have these special safety characteristics are identified in the Parts List of Service Manual. Electrical components having such features are identified by shading on the schematics and by ( $\Delta$ ) on the Parts List in the Service Manual. The use of a substitute replacement which does not have the same safety characteristics as the recommended replacement part shown in the Parts List of Service Manual may cause shock, fire, or other hazards.
4. The leads in the products are routed and dressed with ties, clamps, tubing's, barriers and the like to be separated from live parts, high temperature parts, moving parts and / or sharp edges for the prevention of electric shock and fire hazard. When service is required, the original lead routing and dress should be observed, and it should be confirmed that they have been returned to normal, after re-assembling.

## WARNING

1. The equipment has been designed and manufactured to meet international safety standards.
2. It is the legal responsibility of the repairer to ensure that these safety standards are maintained.
3. Repairs must be made in accordance with the relevant safety standards.
4. It is essential that safety critical components are replaced by approved parts.
5. If mains voltage selector is provided, check setting for local voltage.

# SPECIFIC SERVICE INSTRUCTIONS

## DISASSEMBLY PROCEDURE

### CAUTION

Even with the power switch turn off, some parts of in this unit are live. Be sure to disconnect the power plug from the AC outlet before disassembly and reassembly.

### REMOVING THE TOP COVER

1. As shown in Fig.3, remove the 8 screws marked (A) .
2. Slightly spread the bottom of the top cover.
3. Shift the cover rearward and raise it upward to remove it.

### REMOVING THE REAR PANEL

- After removing the top cover.
1. Remove the 8 screws marked (B) .
  2. Remove the screw marked (C) attached the FBT.
  3. Remove the screw marked (D) attached the SIGNAL PWB with the terminal bracket.
  4. Remove the 5 screws marked (E) attached the terminals with the terminal bracket.
  5. Remove the screw marked (F) attached the terminal bracket with the chassis base.
  6. Remove the 2 hexagonal screws marked (G) attached the D-SUB terminal with the terminal bracket.
  7. As shown in Fig.1, lift the rear panel and remove the claw marked (H) from the terminal bracket.
  8. Shift the top portion of the rear panel slightly rearward and raise it upward to remove it.

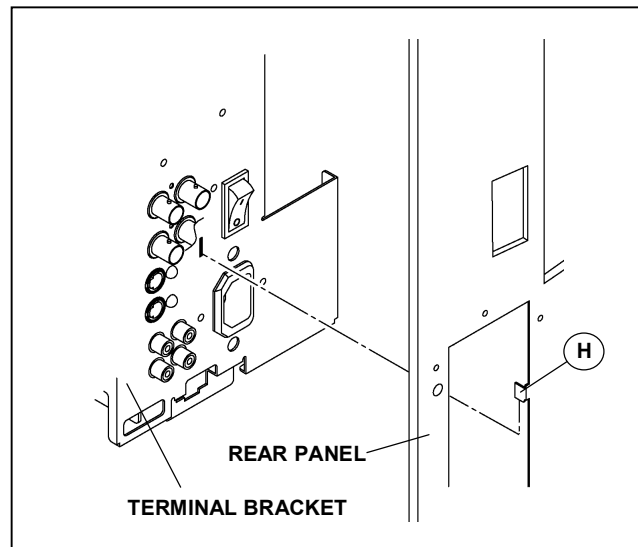

Fig.1

### REMOVING THE TERMINAL BRACKET

- Remove the top cover and rear panel.
1. Pull the PW connector out from the MAIN PWB, connected between the main power switch and MAIN PWB.
  2. As shown in Fig.2, raise the claw marked (J) positioned back side of the chassis base, and lift the terminal bracket from the chassis base.
  3. Slightly shift the terminal bracket rearward and raise it upward to remove it.

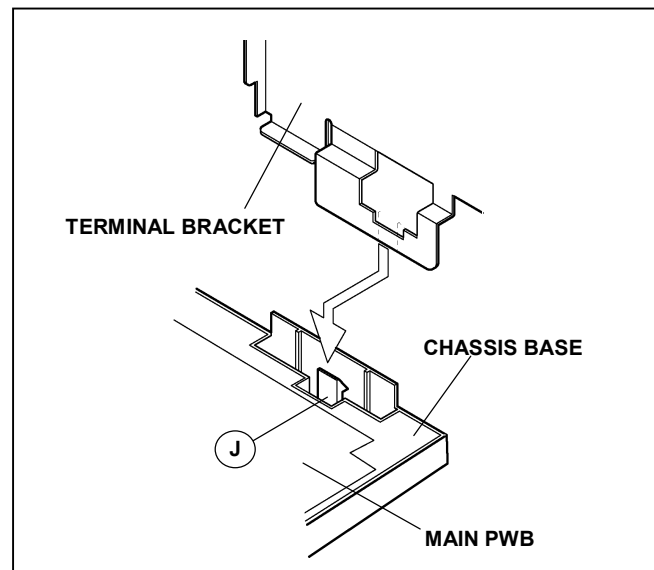

Fig.2

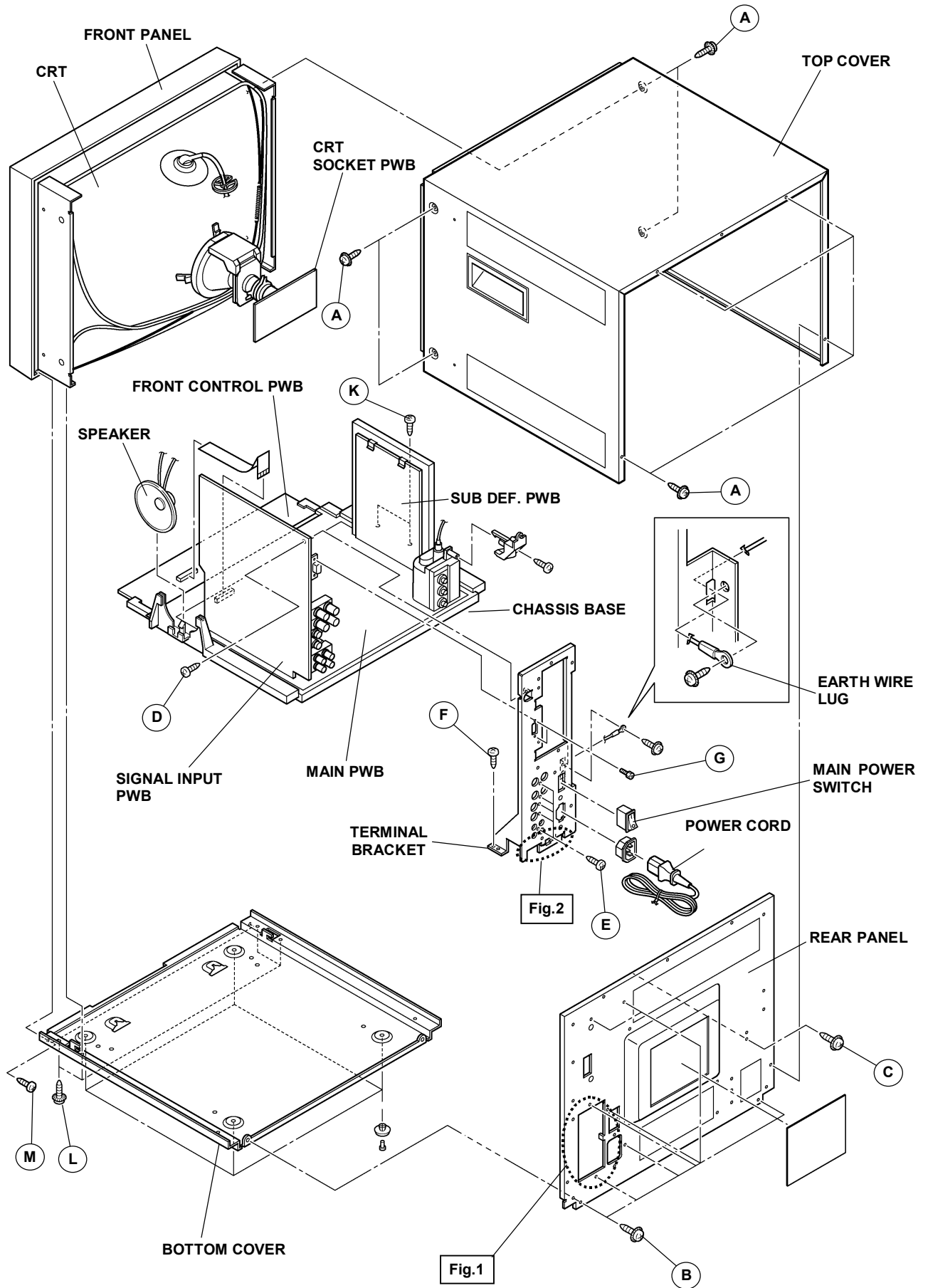

Fig.3

### REMOVING THE CHASSIS BASE

- Remove the top cover, rear panel and terminal bracket.
1. Fall the unit down side ways as able to see the bottom side.
  2. Lift the back side of the chassis base slightly, and separate it from bottom cover.
  3. Raise the **2** claws positioned bottom of the chassis base, and dettach the chassis base from bottom cover.
  4. Then pull the chassis base out to rearward.

### REMOVING THE SUB DEF. PWB

- Remove the top cover.
1. Remove the **2** screws marked **(K)**.
  2. Dettach the connector connected SUB DEF. PWB and MAIN PWB.
  3. Then remove the SUB DEF. PWB.

### REMOVING THE BOTTOM COVER

- Remove the chasssis base.
1. Set the CRT front surfase downward, and stand the bottom cover to facing it toward you.  
At this time, care must be exercised not to damage the front panel and CRT surface.
  2. Remove the **4** screws marked **(L)** and **2** screws marked **(M)**.
  3. While spreading the bottom cover to the bottom side, pull it out to rearward to remove it.

### REMOVING THE SPEAKER

- Remove the top cover.
1. Slightly spread the claws of the speaker holder, and pull up the speaker to remove it.

### A METHOD OF ERECTING THE CHASSIS BASE

To check the PW board from back side.

- (1) Remove the chassis base and the other PW boards.
- (2) Erect the chassis base vertically so that you can easily check the PW board from back side.

### CAUTION

- Before turning on power, make sure that the earth wire properly connected to the terminal bracket, which is attached the main power switch and AC inlet. (Fig.4)
- And make sure that the CRT earth wire and the other connectors are properly connected.
- When erecting the chassis base, be careful so that there will be no contacting with the other PW board.
- Be careful while erecting the PW board, because easily fall down.

### WIRE CLAMPING AND CABLE TYING

1. Be sure to clamp the wire.
2. Never remove the cable tie used for tying the wires together.  
Should it be inadvertently removed, be sure to tie the wires with a new cable tie.

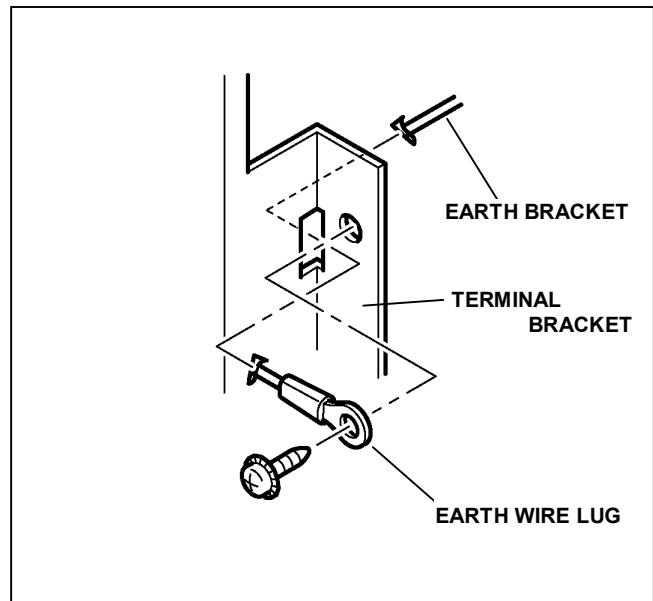

Fig.4



# REPLACEMENT OF MEMORY IC

## 1. MEMORY IC

This model uses memory IC. In the memory IC, memorized data for correctly operating for the video-chroma, deflection and the other control circuits.

When replacing memory IC, be sure to use the IC written with the initial values of data.

## 2. PROCEDURE FOR REPLACING MEMORY IC

### (1) Power off

Turn the power off and unplug the power plug from the AC outlet.

### (2) Replace IC

Be sure to use the memory IC written with the initial setting data.

### (3) Power on

Connect the power plug into the AC outlet and turn the power on.

### (4) Check and set SET-UP MENU items

- 1) Press the **MENU** key and the **CHROMA/PHASE** key simultaneously.
- 2) The SET-UP MENU screen (Fig. 1) will be displayed.
- 3) Check the setting value of the each item of the SET-UP MENU. If value is different, select it and set the correct value.
- 4) Press the **MENU** key, and return to the normal screen.

### (5) Check and set MENU items

Press the **MENU** key and check the setting value of the each item. If the value is different, select the item and set the correct value.

### (6) Adjust the front control items

Adjust the CHROMA, PHASE, CONTRAST and BRIGHT. Not all items can be adjusted as expected if the signal has not been input correctly in the adjustments.

### (7) Confirm the items of SERVICE MENU

Confirm the each item of the SERVICE MENU. Refer to the corresponding page to operate the SERVICE MENU.

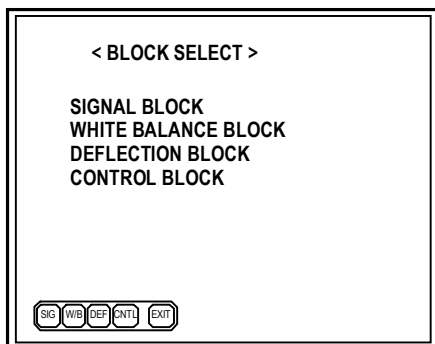
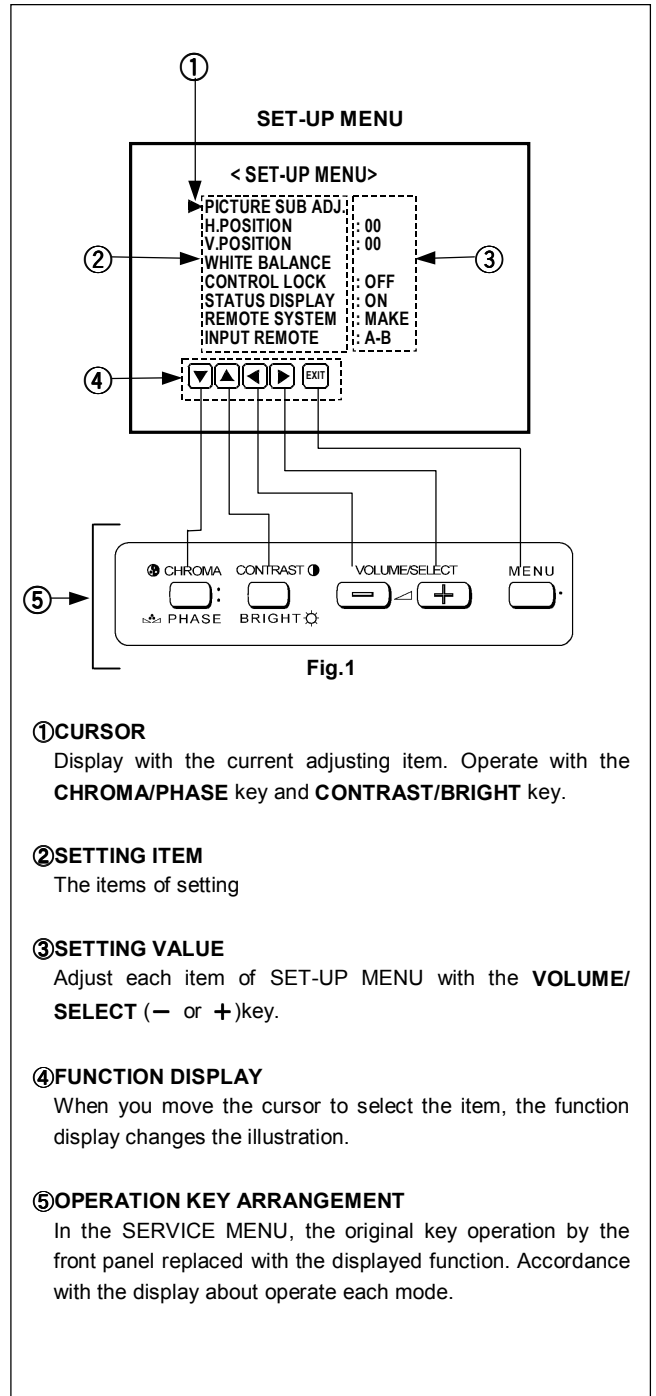

**SERVICE MENU**  
**<BLOCK SELECT> SCREEN**

**INITIAL SETTING VALUE OF THE SET-UP MENU**

Setting item	Setting content / Range	Initial setting value
PICTURE SUB ADJ.	CONTRAST	00
	BRIGHT	00
	PHASE	00
	CHROMA	00
H. POSITION	-05 ~ +05	00
V. POSITION	-05 ~ +05	00
WHITE BALANCE	CUTOFF (R / G / B)	-20 ~ +20
	DRIVE (R / B)	-20 ~ +20
CONTROL LOCK	→ ON → OFF ←	OFF
STATUS DISPLAY	→ ON → OFF ←	ON
REMOTE SYSTEM	→ MAKE → TRG. ←	MAKE
INPUT REMOTE	→ A/D → A/B ←	A-B

**INITIAL SETTING VALUE OF THE MENU**

Setting item	Setting content / Range	Initial setting value
SHARPNESS	00 ~ +40	00
ADJ. BAR POSI	→ LOWER → UPPER ←	LOWER
COLOUR TEMP	→ 9300 → 6500 ←	9300
COLOUR SYSTEM	→ AUTO → NTSC → AUTO → PAL ←	AUTO
RUSH DELAY	→ STD. → SLOW ←	STD.
ASPECT RATIO	→ 4-3. → 16-9 ←	4-3

**INITIAL SETTING OF FRONT PANEL CONTROLS**

Control item	Initial setting value
INPUT SELECT	A
UNDER SCAN	OFF
MENU	OFF
VOLUME	20
CONTRAST	00
BRIGHT	00
PHASE	00
CHROMA	00

## BLOCK SELECT ITEMS

It is no requirement for adjustment about  part in the table. Don't change the values.

### SIGNAL BLOCK

ITEM	INPUT SIGNAL	CONTENTS
S01	VIDEO	BRIGHT
S02		CONTRAST
S03		CHROMA(PAL)
S04		CHROMA(NTSC)
S05		PHASE(NTSC)
S06	COMPONENT	CHROMA
S07	RGB	BRIGHT
S08		CONTRAST
S09	UNDER SCAN	BRIGHT
S10		CONTRAST
S11	VIDEO	PHASE(PAL)
S12	COMPONENT	PHASE
S13	VIDEO	CONT TRACKING

### DEFLECTION BLOCK

ITEM	ASPECT RATIO SCAN SIZE	VERTICAL FREQUENCY	CONTENTS
D01	4:3  NORMAL SCAN	50Hz	HORIZONTAL POSITION
D02			HORIZONTAL SIZE
D03			VERTICAL POSITION
D04			VERTICAL SIZE
D05			VERTICAL LINEARITY
D06			VERTICAL S-CORRECTION
D07			E-W PARABOLA
D08			E-W CORNER
There are many mode of the DEFLECTION BLOCK except for above DA1~DA8 (4:3 / 60Hz), DB1~DB8 (16:9 / 50Hz) DC1~DC8 (16:9 / 60Hz) DD1~DD8 (UNDER SCAN / 50Hz) DE1~DE8 (UNDER SCAN / 60Hz) DF7~DF8 (16:9 UNDER SCAN / 50Hz) DG7~DG8 (16:9 UNDER SCAN / 60Hz)			

### WHITE BALANCE BLOCK

ITEM	INPUT SIGNAL	CONTENTS
W01	VIDEO COMPOSITE SIGNAL	R CUTOFF
W02		G CUTOFF
W03		B CUTOFF
W04		R DRIVE (6500K)
W05		B DRIVE (6500K)
W06		R DRIVE (9300K)
W07		B DRIVE (9300K)
W08	COMPONENT SIGNAL (Input from rear slot card)	R CUTOFF
W09		G CUTOFF
W10		B CUTOFF
W11		R DRIVE (6500K)
W12		B DRIVE (9300K)
W13		R DRIVE (6500K)
W14		B DRIVE (9300K)
W15	RGB SIGNAL (Input from rear slot card)	R CUTOFF
W16		G CUTOFF
W17		B CUTOFF
W18		R DRIVE (6500K)
W19		B DRIVE (9300K)
W20		R DRIVE (6500K)
W21		B DRIVE (9300K)
W22	UNDER SCAN	R CUTOFF
W23		G CUTOFF
W24		B CUTOFF

### CONTROL BLOCK (Don't change the values, because all fixed)

ITEM	CONTENTS	
C01	DESTINATION (0 : For Japan, 1 : For Europe / US)	
C02	BRIGHT POINT	UPPER
C03		LOWER
C04	CONTRAST POINT	UPPER
C05		LOWER
C06	CHROMA POINT	UPPER
C07		LOWER
C08	PHASE POINT	UPPER
C09		LOWER
C10	OSD HORIZONTAL POSITION	
C11	OSD VERTICAL FREQUENCY 50Hz	
C12	OSD VERTICAL FREQUENCY 60Hz	
C13	HORIZONTAL CENTER (RGB)	
C14	HORIZONTAL CENTER (COMPONENT)	
C15	BRIGHT SERVICE	
C16	SHARPNESS CENTER	
C17	HVT H	
C18	HVT V	
C19	HVT H (UNDER SCAN)	
C20	HVT V (UNDER SCAN)	
C21	V-S. CORRECTION	
C22	TRAPEZOID	
C23	HOUR METER	
C24	RUSH DELAY	
C25	DEGAUSS DELAY TIME	
C26~C33	SLOT IDENTIFY	

# SERVICE ADJUSTMENTS

## BEFORE STARTING SERVICE ADJUSTMENT

1. Confirm the proper AC power voltage is being supplied.
2. Supply power to the set and measuring instruments and allow to warm up for at least 30 minutes.
3. The setting is made on basis of the initial setting values. The setting values which adjust the screen to the optimum condition can be different from the initial setting values.
4. Use care not to disturb controls and switches not mentioned in the adjustment items.

## FOCUS AND SCREEN ADJUSTMENT HOLES

Because of adjusting FOCUS VR1, 2 and SCREEN VR without disassembled the monitor cabinet, there are the adjustment holes on the backside of the monitor cabinet (rear panel). Be sure to use a non-metallic driver for adjusting there VRs. The metallic driver can cause damage by shorting.

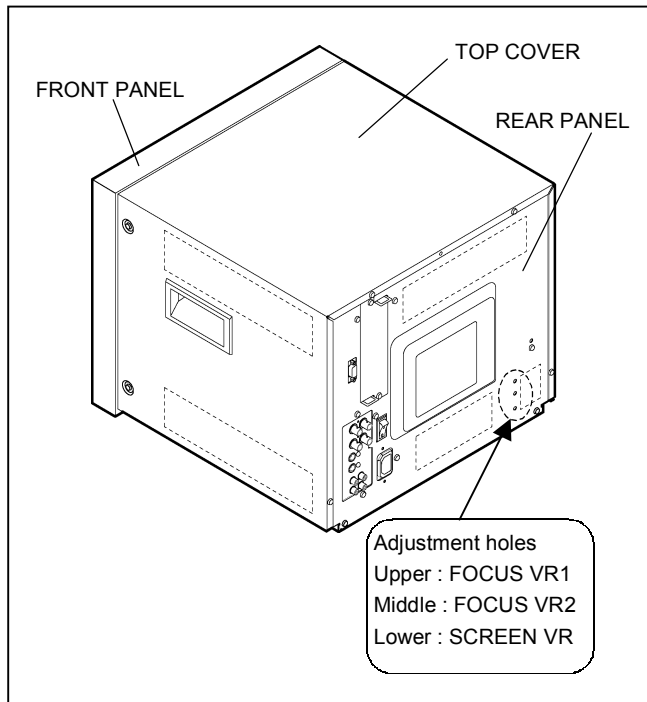

## ADJUSTMENT ITEMS

### BASIC ADJUSTMENT

- Checking of B1 voltage
- Checking of High voltage
- Focus adjustment

### VIDEO / CHROMA CIRCUIT ADJUSTMENT

- White Balance (Low Light) adjustment
- White Balance (High Light 6500K) adjustment
- White Balance (High Light 9300K) adjustment
- Bright adjustment
- Contrast adjustment
- PAL Chroma adjustment
- NTSC 3.58 Chroma adjustment
- NTSC 3.58 Phase adjustment

### DEFLECTION CIRCUIT ADJUSTMENT

- Horizontal center adjustment
- Horizontal size adjustment
- Side pincushion adjustment
- Vertical center adjustment
- Vertical linearity adjustment
- Vertical size adjustment
- 16:9 Vertical size adjustment
- 16:9 Side pin cushion adjustment
- Under scan horizontal size, horizontal center adjustment
- 16 : 9 Under scan side pincushion adjustment

## MEASURING INSTRUMENTS AND STANDARD SIGNAL

- DC voltmeter (digital voltmeter)
- High voltage meter
- Oscilloscope
- Colour temperature meter or Colour analyser
- COMPONENT / RGB input card (IF-C01COM)
- Signal generator (PAL/NTSC systems)

The waveforms of signals refer to the following figure.

### STANDARD VIDEO SIGNALS FOR ADJUSTMENT

#### COMPOSITE VIDEO SIGNAL (PAL / NTSC colour bar)

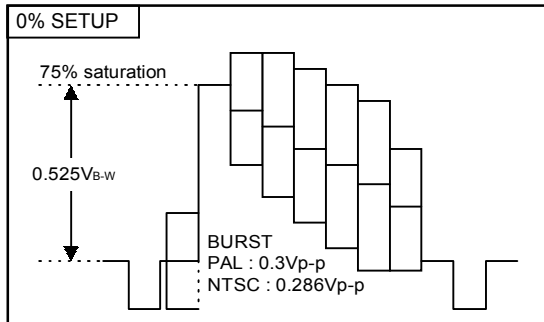

#### Y / C Separate signal (colour bar)

##### Chroma

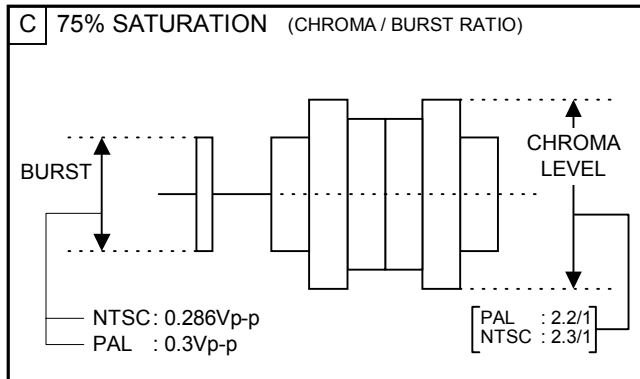

##### Luminance

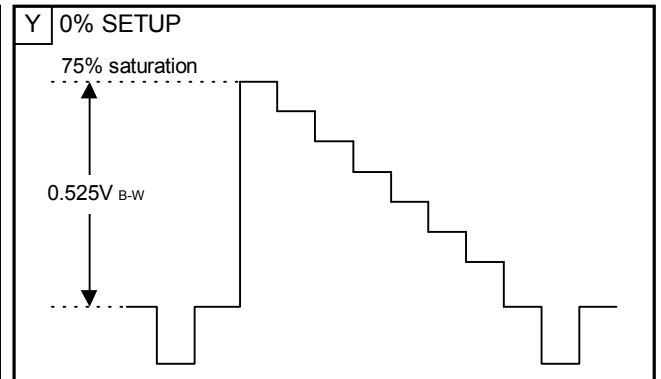

# ADJUSTMENT LOCATIONS

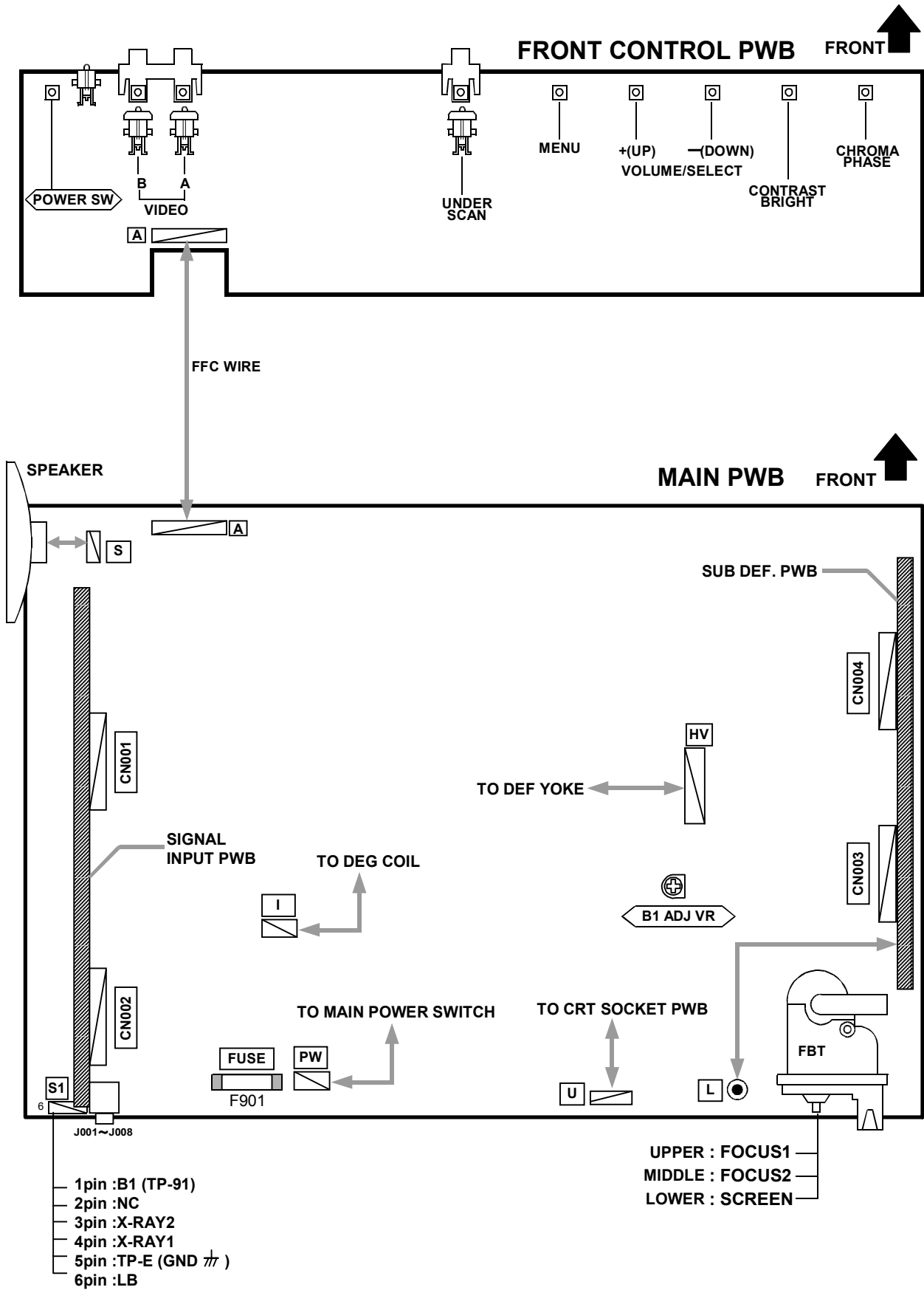

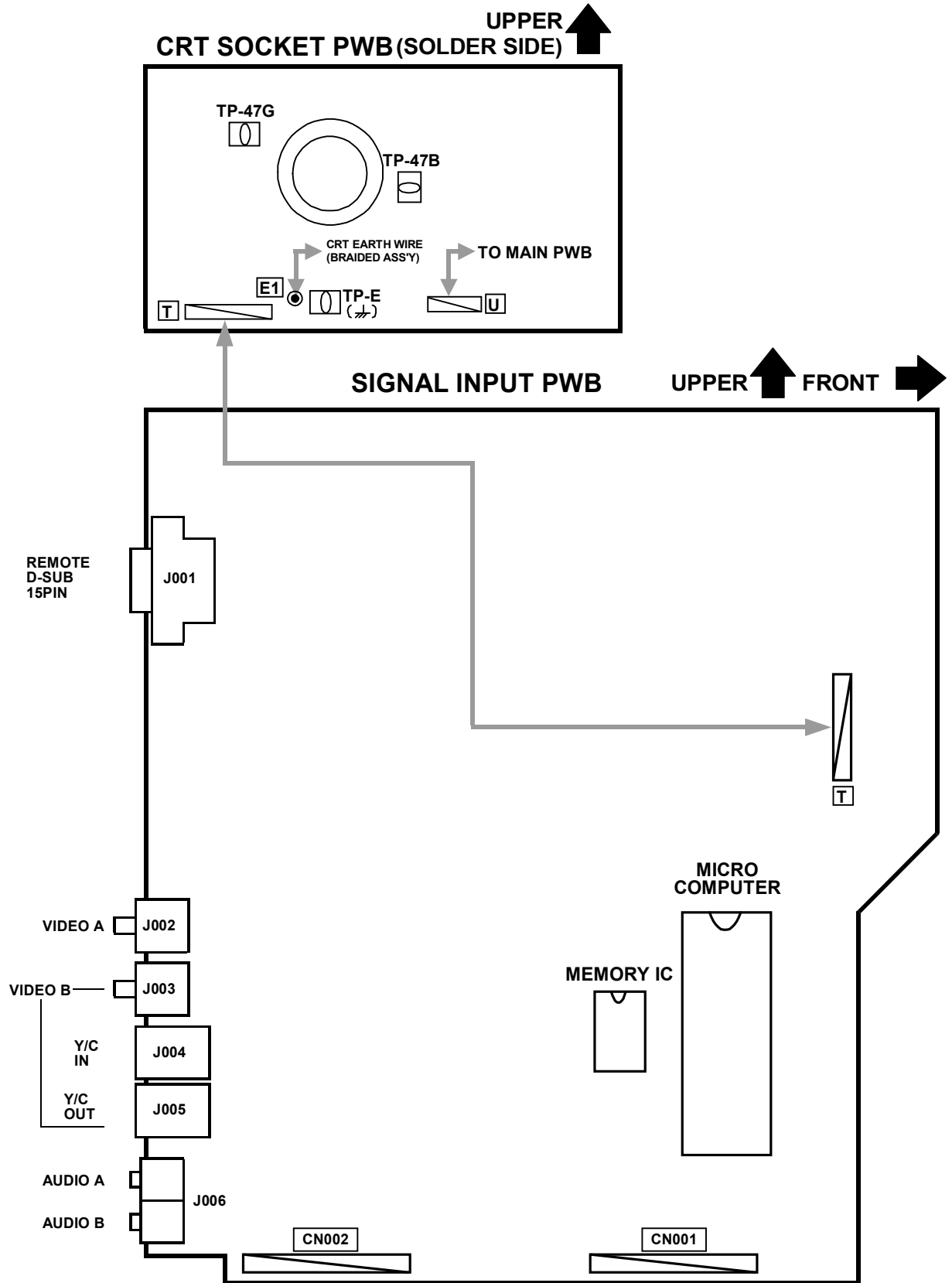

## BASIC OPERATION OF SERVICE MENU

### 1. SERVICE MENU ITEMS

With the SERVICE MENU, various settings can be made, and they are broadly classified in the following items of adjustments. It is no requirement for adjustment the portion of the DEFLECTION BLOCK and CONTROL BLOCK.

- SIGNAL BLOCK** ..... This block adjusts the data of the various signal circuit controls.
- WHITE BALANCE BLOCK**... This block adjusts the data of the WHITE BALANCE adjustment.
- DEFLECTION BLOCK**..... This block adjusts the data of the DEFLECTION circuit.
- CONTROL BLOCK** ..... This block adjusts the whole of the systems  
(This block is a fixed value. Don't adjust it.)

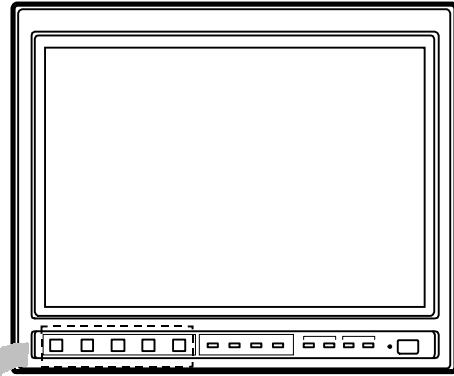

### 2. BASIC OPERATION OF THE SERVICE MENU

#### (1) HOW TO ENTER THE SERVICE MENU

- ① Press **MENU** key and **VOLUME/SELECT + (UP)** key simultaneously (Fig. 1).  
The letter "S" appears at the upper left of the screen (Fig. 2).
- ② While displaying the letter "S", press **MENU** key and **CHROMA/PHASE** key simultaneously (Fig.1).  
The screen display "PLEASE DON'T TOUCH" (Fig. 3).
- ③ WHILE displaying the letters above-mentioned, press **VOLUME/SELECT + (UP) key** or **– (DOWN) key** to display the SERVICE MENU as shown in Fig. 4.  
If above-mentioned steps or state continues for more than 5 seconds without a further operation, the display extinguishes and the mode is released.

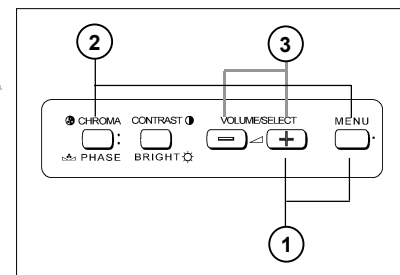

Fig.1

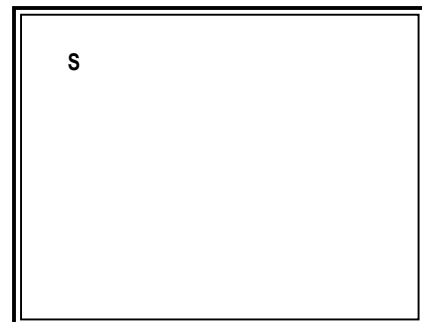

Fig. 2



Fig. 3

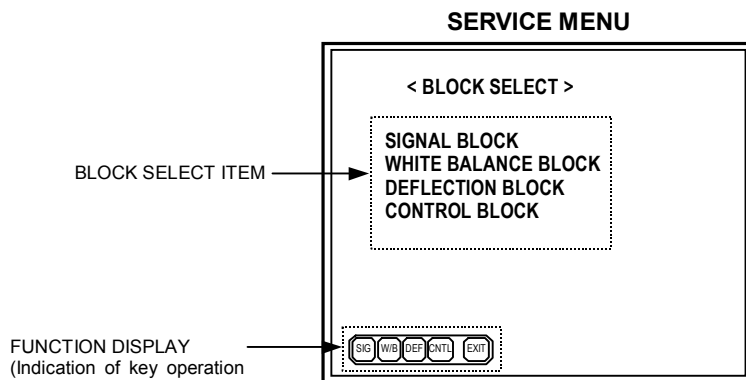
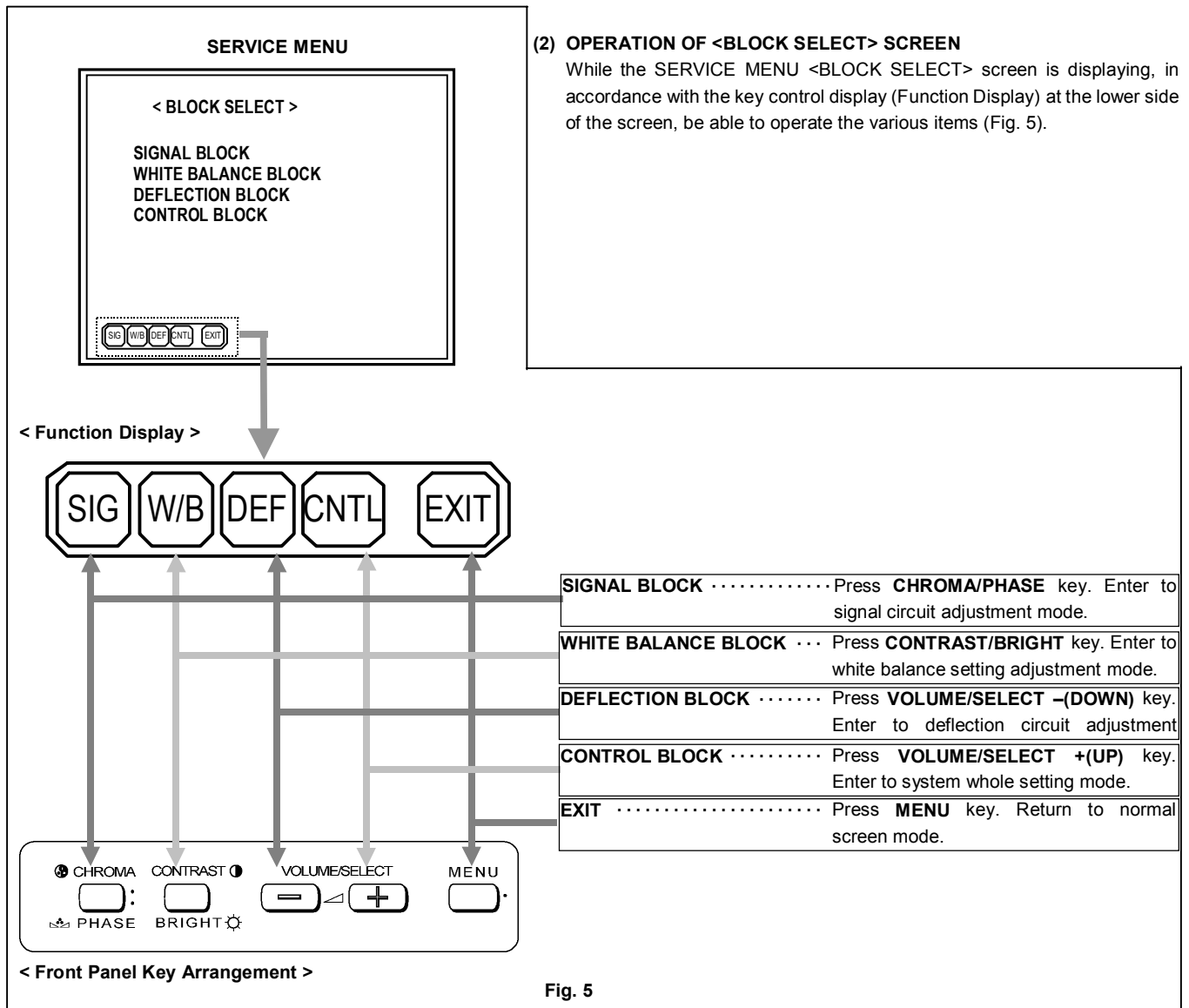

Fig. 4







**(2) OPERATION OF <BLOCK SELECT> SCREEN**

While the SERVICE MENU <BLOCK SELECT> screen is displaying, in accordance with the key control display (Function Display) at the lower side of the screen, be able to operate the various items (Fig. 5).

Fig. 5

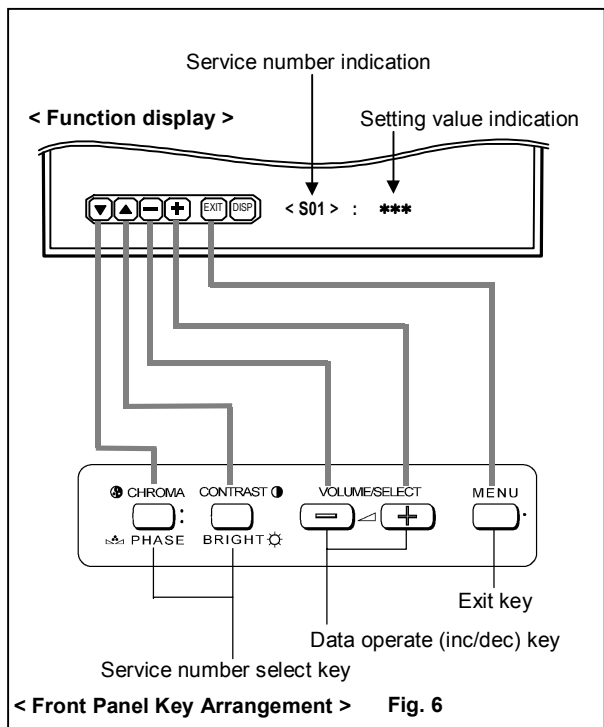

**< For example as following, explaining about SIGNAL BLOCK key operations. >**

**(3) SELECT THE SERVICE NUMBER**

Press the **CHROMA/PHASE** or **CONTRAST/BRIGHT** key to select the service number.

**(4) ADJUSTMENT DATA OPERATION**

Press the **VOLUME/SELECT + (UP)** key to change the setting value in the + direction.

Press the **VOLUME/SELECT - (DOWN)** key to change the setting value in the - direction.

**(5) EXIT SERVICE MENU**

When adjustments are completed, press **MENU** key then return to the BLOCK SELECT screen. Again press **MENU** key then return to the normal screen. The setting values are automatically memorized.

Fig. 6

### 3. HOW TO OPERATE EACH SERVICE MENU ITEMS

#### ■ SIGNAL BLOCK

- ① In the <BLOCK SELECT> screen, press the **CHROMA/PHASE** key.
- ② Then SIGNAL BLOCK adjustment mode screen is displayed (Fig. 7).
- ③ The original front key function replaced with the different function displayed at the lower side of the screen as shown below.  
Refer to the illustration given below, the function about each key in this mode.
- ④ In this mode, **UNDER SCAN** key is the switch of the screen display. If necessary, you can shut off the display. Carefully, values of adjustment items are changed while shut off the screen display.
- ⑤ Press the **MENU** key, then exit the SIGNAL BLOCK screen to return to the <BLOCK SELECT> screen.

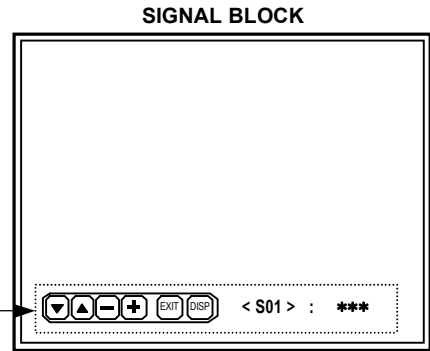
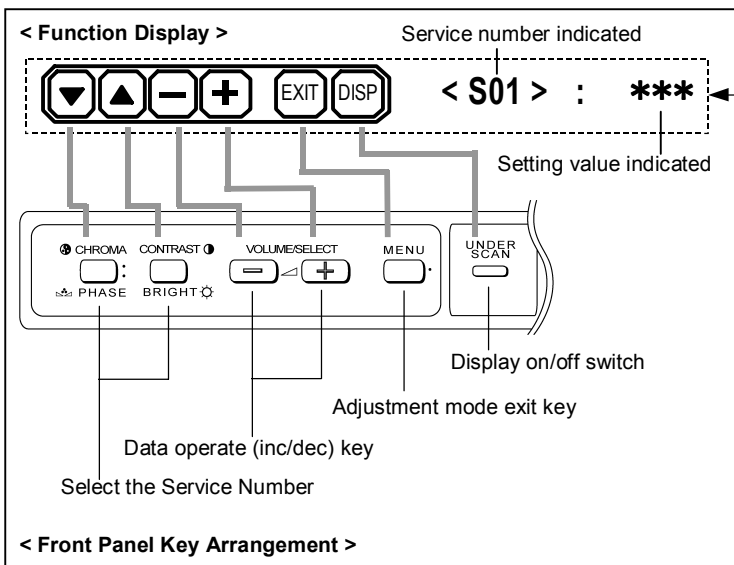

Fig. 7



#### ■ WHITE BALANCE BLOCK

- ① In the <BLOCK SELECT> screen, press the **CONTRAST/BRIGHT** key.
- ② Then WHITE BALANCE menu screen is displayed (Fig. 8).
- ③ In this case, key function is replaced as shown below. There are several modes of WHITE BALANCE adjustment. Select the various WHITE BALANCE mode from this menu screen.
- ④ Press the **MENU** key few times, then exit from the WHITE BALANCE BLOCK screen to return to the <BLOCK SELECT> screen.

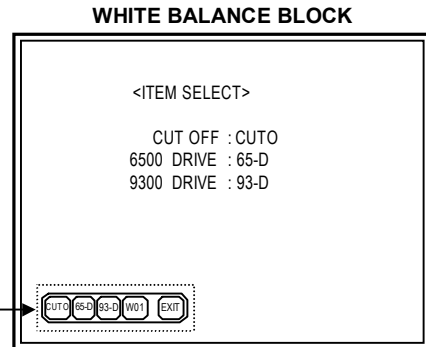
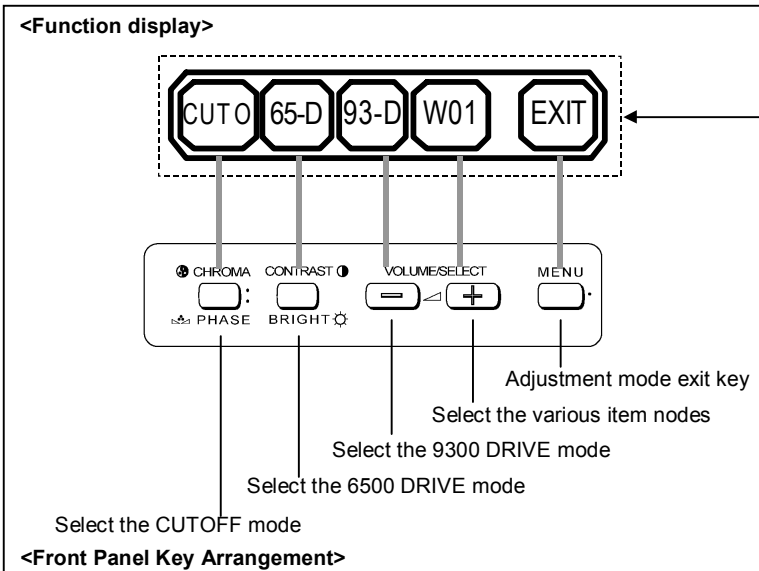

Fig.8



[ WHITE BALANCE Adjustment : METHOD 1 ]

Accordance with the screen display, select the each WHITE BALANCE mode following below.

**CUTOFF adjustment mode (Low light adjustment)**

- ① In the WHITE BALANCE menu screen, press the **CHROMA/PHASE** key to enter to the CUTOFF adjustment mode (Fig. 9). In this case, key function is replaced as shown below.
- ② Whenever press the **CHROMA/PHASE** key, change the adjustment colour of R, G and B.
- ③ The single horizontal line service screen appears if press the **CONTRAST/BRIGHT** key (Fig. 10).
  - Refer to the "Low-Light adjustment" corresponding page about detailed adjustment steps.

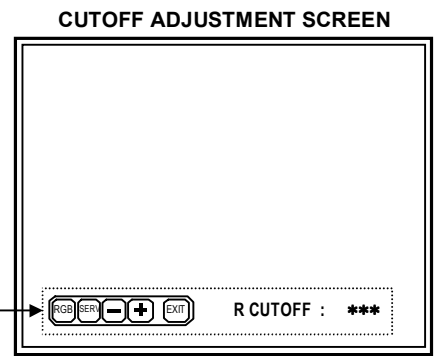
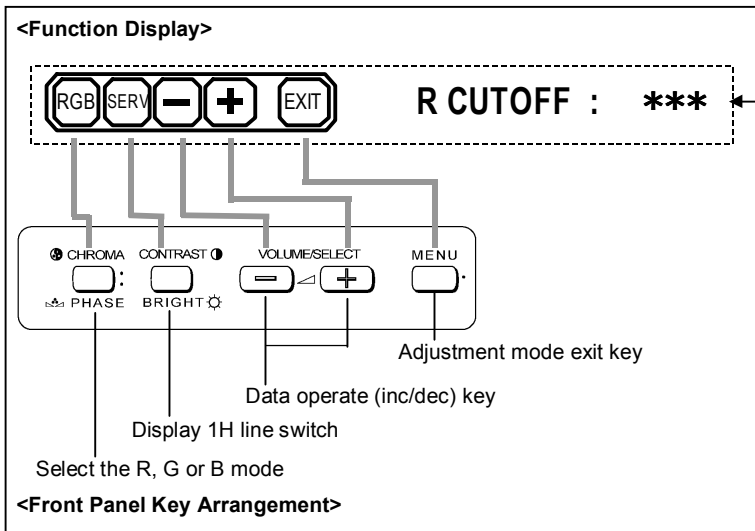

Fig.9

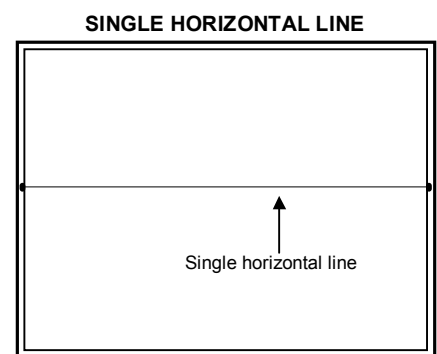

Fig.10

**DRIVE adjustment mode (HIGH LIGHT)**

- ① In the WHITE BALANCE menu screen, press the **CONTRAST/BRIGHT** key to enter to the 6500 DRIVE adjustment mode (Fig. 11). In this case, press the **VOLUME/SELECT (-)** key, enter to 9300 DRIVE mode.
- ② Whenever press the **CHROMA/PHASE** key, change the "R DRIVE" or "B DRIVE" adjustment mode.
- ③ **CONTRAST/ BRIGHT** key is the switch of the screen display. If necessary, you can shut off the display. Carefully, values of adjustment items are changed while shut off the screen display.
  - Refer to the "High-Light adjustment" corresponding page about detailed adjustment steps.

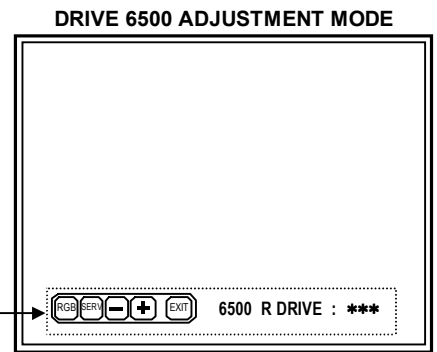
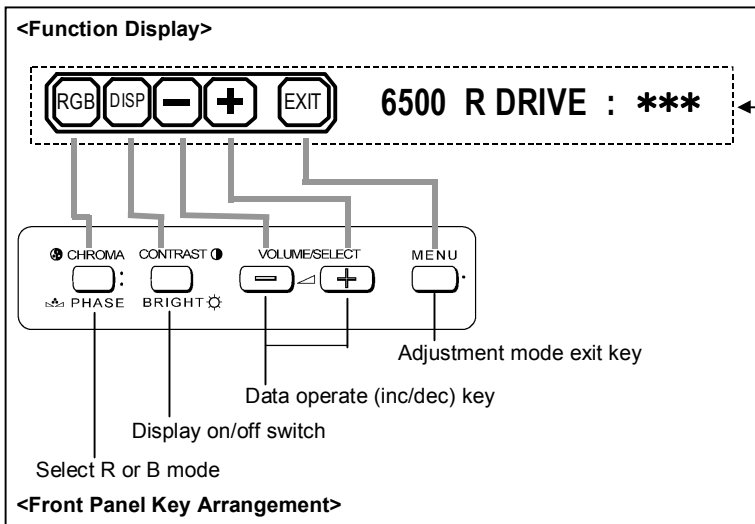

Fig.11

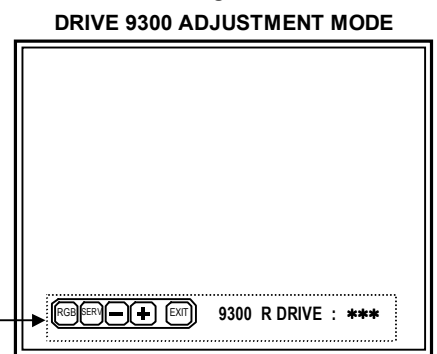

Fig.12

**[WHITE BALANCE Adjustment : METHOD 2]**

SERVICE MENU has the other method for adjusting the WHITE BALANCE.

- ① In the WHITE BALANCE menu screen, press the **VOLUME/SELECT + (UP)** key, then enter to the "W01" adjustment mode (Fig. 13).
- ② Whenever press the **CHROMA/PHASE** key, change the adjustment mode from W01 to W24. And change the adjustment value by pressing the **VOLUME/SELECT (- or +)** keys.

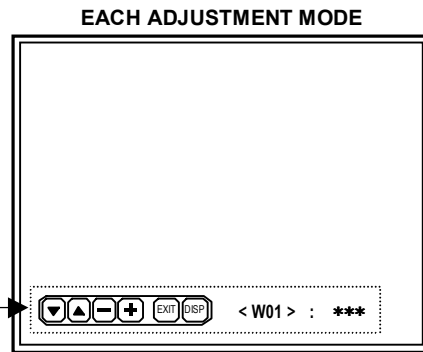
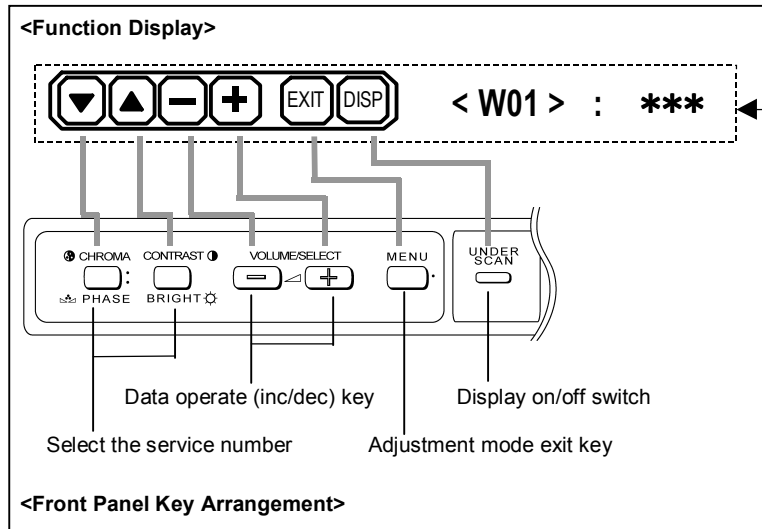

Fig.13

■ DEFLECTION BLOCK

- ① In the <BLOCK SELECT> screen, press the **VOLUME/SELECT - (DOWN)** key.
- ② Then the DEFLECTION BLOCK adjustment screen is displayed (Fig. 14). The indication service number on the screen are changed by the vertical frequency, aspect ratio and scan size of signal for adjustment.
- ③ The original front key function replaced with the other function displayed at the lower side of the screen as shown below.

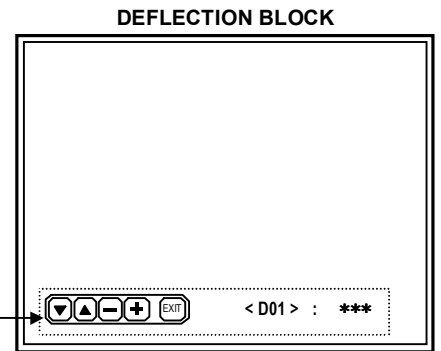
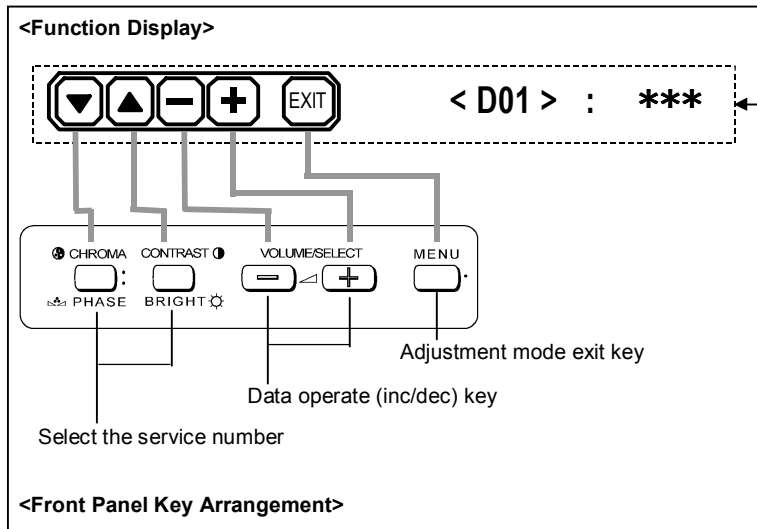

Fig.14



■ CONTROL BLOCK

In the CONTROL BLOCK, there are several setting items for decide the whole system condition. It is no requirement for adjustment in this block. Please not to change the values. If you had changed the values, you should put back the values by the method as following.

- ① In the <BLOCK SELECT> screen, press the **VOLUME/SELECT +(UP)** key.
- ② Then the CONTROL BLOCK adjustment screen is displayed (Fig. 15).
- ③ The original front key function replaced with the other function displayed at the lower side of the screen as shown below.

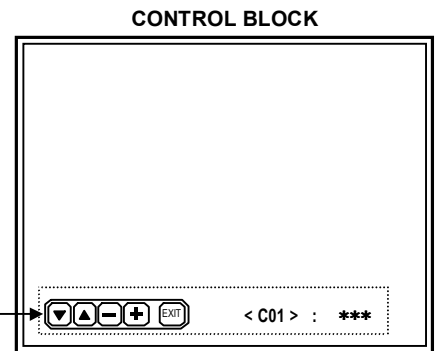
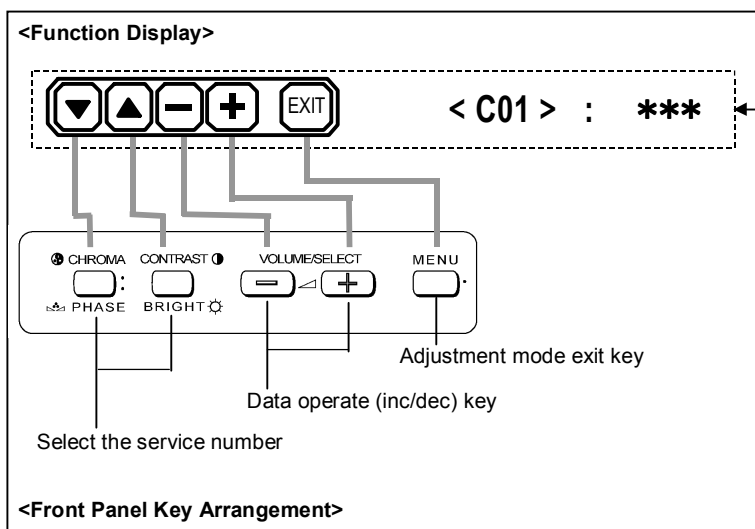
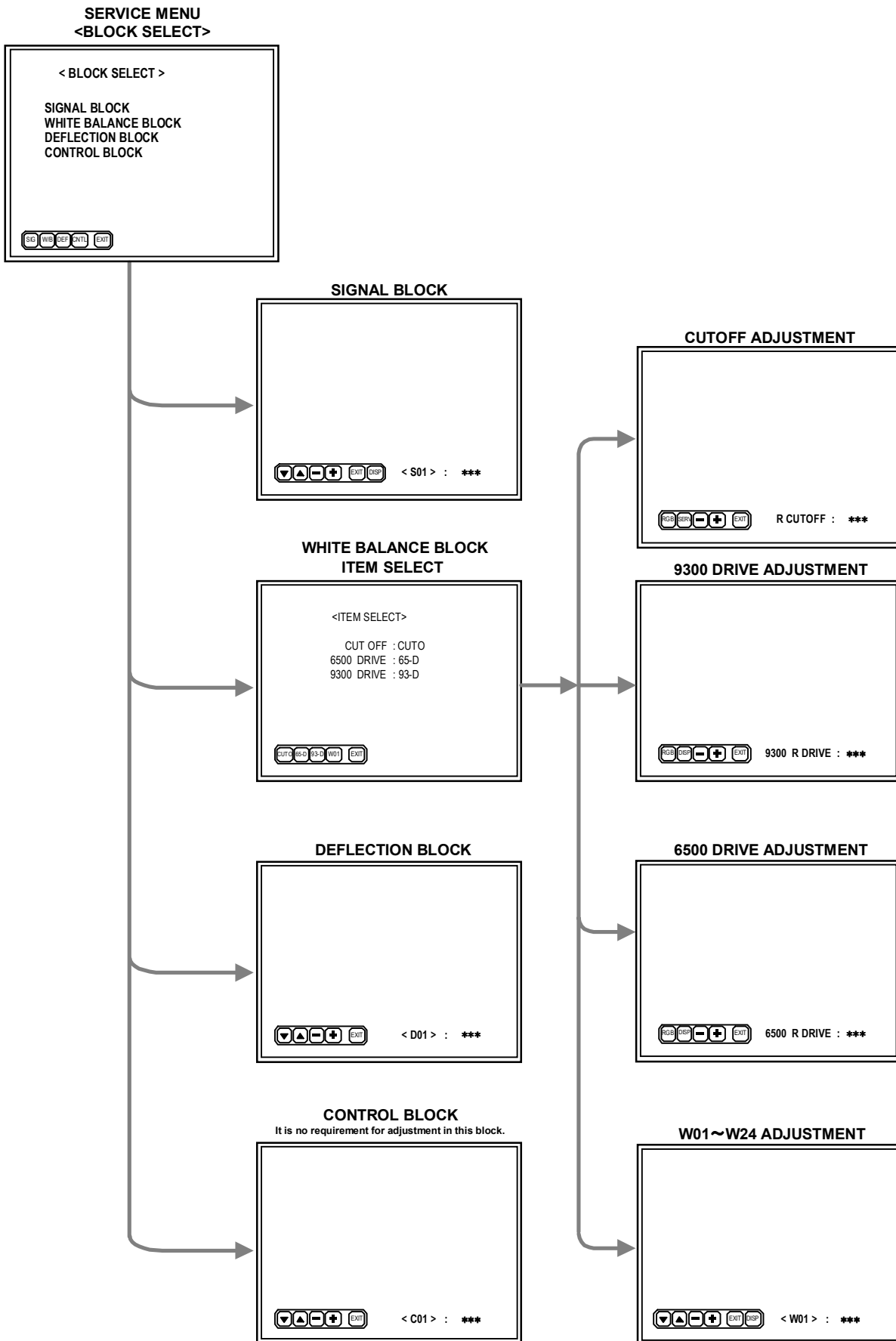

Fig. 15



### 4. SERVICE MENU FLOW CHART



## INITIAL SETTINGS OF THE SERVICE MENU

It is no requirement for adjustment of the  part of the tables. Don't change the values.

### SIGNAL BLOCK

Item	Input Signal	Contents	Variable Range	Attribute	Initial Value
S01	VIDEO	BRIGHT	000 ~ 255	ABSOLUTE	138
S02		CONTRAST	000 ~ 127	ABSOLUTE	081
S03		CHROMA(PAL)	000 ~ 127	ABSOLUTE	064
S04		CHROMA(NTSC)	000 ~ 127	ABSOLUTE	063
S05		PHASE(NTSC)	000 ~ 127	ABSOLUTE	061
S06	COMPONENT	CHROMA	000 ~ 127	ABSOLUTE	052
S07	RGB	BRIGHT	000 ~ 127	ABSOLUTE	070
S08		CONTRAST	-128 ~ 000 ~ +127	OFFSET	-006
S09	UNDER SCAN	BRIGHT	-128 ~ 000 ~ +127	OFFSET	000
S10		CONTRAST	-128 ~ 000 ~ +127	OFFSET	-009
S11	VIDEO	PHASE(PAL)	000 ~ 127	FIXED	063
S12	COMPONENT	PHASE	000 ~ 127	FIXED	063
S13	VIDEO	CONT TRACKING	00 ~ 31	FIXED	016

### WHITE BALANCE BLOCK

Item	Input Signal	Contents	Variable Range	Attribute	Initial Value
W01	VIDEO	R CUTOFF	000 ~ 255	ABSOLUTE	050
W02		G CUTOFF	000 ~ 255	ABSOLUTE	050
W03		B CUTOFF	000 ~ 255	ABSOLUTE	050
W04		R DRIVE (6500)	000 ~ 127	ABSOLUTE	080
W05		B DRIVE (6500)	000 ~ 127	ABSOLUTE	048
W06		R DRIVE (9300)	000 ~ 127	ABSOLUTE	065
W07		B DRIVE (9300)	000 ~ 127	ABSOLUTE	055
W08	COMPONENT (REAR SLOT INPUT)	R CUTOFF	-128 ~ 000 ~ +127	OFFSET	000
W09		G CUTOFF	-128 ~ 000 ~ +127	OFFSET	000
W10		B CUTOFF	-128 ~ 000 ~ +127	OFFSET	000
W11		R DRIVE (6500)	-128 ~ 000 ~ +127	OFFSET	000
W12		B DRIVE (9300)	-128 ~ 000 ~ +127	OFFSET	000
W13		R DRIVE (6500)	-128 ~ 000 ~ +127	OFFSET	000
W14		B DRIVE (9300)	-128 ~ 000 ~ +127	OFFSET	000
W15	RGB (REAR SLOT INPUT)	R CUTOFF	-128 ~ 000 ~ +127	OFFSET	000
W16		G CUTOFF	-128 ~ 000 ~ +127	OFFSET	000
W17		B CUTOFF	-128 ~ 000 ~ +127	OFFSET	000
W18		R DRIVE (6500)	-128 ~ 000 ~ +127	OFFSET	000
W19		B DRIVE (9300)	-128 ~ 000 ~ +127	OFFSET	000
W20		R DRIVE (6500)	-128 ~ 000 ~ +127	OFFSET	000
W21		B DRIVE (9300)	-128 ~ 000 ~ +127	OFFSET	000
W22	UNDER SCAN	R CUTOFF	-128 ~ 000 ~ +127	OFFSET	000
W23		G CUTOFF	-128 ~ 000 ~ +127	OFFSET	000
W24		B CUTOFF	-128 ~ 000 ~ +127	OFFSET	000

## DEFLECTION BLOCK

Item	Scan size Aspect Ratio	Vertical Frequency	Contents	Variable Range	Attribute	Initial Value
D01	4:3 NORMAL	50Hz	HORIZONTAL POSITION	000 ~ 031	ABSOLUTE	013
D02			HORIZONTAL SIZE	000 ~ 063	ABSOLUTE	046
D03			VERTICAL POSITION	000 ~ 127	ABSOLUTE	037
D04			VERTICAL SIZE	000 ~ 127	ABSOLUTE	068
D05			VERTICAL LINEARITY	000 ~ 031	ABSOLUTE	023
D06			VERTICAL S-CORRECTION	000 ~ 063	ABSOLUTE	042
D07			E-W PARABOLA	000 ~ 063	ABSOLUTE	043
D08			E-W CORNER	000 ~ 031	ABSOLUTE	019
DA1	4:3 NORMAL	60Hz	HORIZONTAL POSITION	-032 ~ 000 ~ +031	OFFSET	+003
DA2			HORIZONTAL SIZE	-064 ~ 000 ~ +063	OFFSET	-005
DA3			VERTICAL POSITION	-128 ~ 000 ~ +127	OFFSET	+002
DA4			VERTICAL SIZE	-128 ~ 000 ~ +127	OFFSET	-002
DA5			VERTICAL LINEARITY	-032 ~ 000 ~ +031	OFFSET	-002
DA6			VERTICAL S-CORRECTION	-064 ~ 000 ~ +063	OFFSET	000
DA7			E-W PARABOLA	-064 ~ 000 ~ +063	OFFSET	000
DA8			E-W CORNER	-032 ~ 000 ~ +031	OFFSET	000
DB1	16:9 NORMAL	50Hz	HORIZONTAL POSITION	-032 ~ 000 ~ +031	OFFSET	000
DB2			HORIZONTAL SIZE	-064 ~ 000 ~ +063	OFFSET	000
DB3			VERTICAL POSITION	-128 ~ 000 ~ +127	OFFSET	000
DB4			VERTICAL SIZE	-128 ~ 000 ~ +127	OFFSET	-031
DB5			VERTICAL LINEARITY	-032 ~ 000 ~ +031	OFFSET	000
DB6			VERTICAL S-CORRECTION	-064 ~ 000 ~ +063	OFFSET	000
DB7			E-W PARABOLA	-064 ~ 000 ~ +063	OFFSET	-021
DB8			E-W CORNER	-032 ~ 000 ~ +031	OFFSET	-002
DC1	16:9 NORMAL	60Hz	HORIZONTAL POSITION	-032 ~ 000 ~ +031	OFFSET	000
DC2			HORIZONTAL SIZE	-064 ~ 000 ~ +063	OFFSET	000
DC3			VERTICAL POSITION	-128 ~ 000 ~ +127	OFFSET	000
DC4			VERTICAL SIZE	-128 ~ 000 ~ +127	OFFSET	-030
DC5			VERTICAL LINEARITY	-032 ~ 000 ~ +031	OFFSET	000
DC6			VERTICAL S-CORRECTION	-064 ~ 000 ~ +063	OFFSET	000
DC7			E-W PARABOLA	-064 ~ 000 ~ +063	OFFSET	-021
DC8			E-W CORNER	-032 ~ 000 ~ +031	OFFSET	-002
DD1	4:3 UNDER SCAN	50Hz	HORIZONTAL POSITION	-032 ~ 000 ~ +031	OFFSET	000
DD2			HORIZONTAL SIZE	-064 ~ 000 ~ +063	OFFSET	-004
DD3			VERTICAL POSITION	-128 ~ 000 ~ +127	OFFSET	000
DD4			VERTICAL SIZE	-128 ~ 000 ~ +127	OFFSET	000
DD5			VERTICAL LINEARITY	-032 ~ 000 ~ +031	OFFSET	000
DD6			VERTICAL S-CORRECTION	-064 ~ 000 ~ +063	OFFSET	000
DD7			E-W PARABOLA	-064 ~ 000 ~ +063	OFFSET	-028
DD8			E-W CORNER	-032 ~ 000 ~ +031	OFFSET	000
DE1	4:3 UNDER SCAN	60Hz	HORIZONTAL POSITION	-032 ~ 000 ~ +031	OFFSET	000
DE2			HORIZONTAL SIZE	-064 ~ 000 ~ +063	OFFSET	-002
DE3			VERTICAL POSITION	-128 ~ 000 ~ +127	OFFSET	000
DE4			VERTICAL SIZE	-128 ~ 000 ~ +127	OFFSET	002
DE5			VERTICAL LINEARITY	-032 ~ 000 ~ +031	OFFSET	000
DE6			VERTICAL S-CORRECTION	-064 ~ 000 ~ +063	OFFSET	000
DE7			E-W PARABOLA	-064 ~ 000 ~ +063	OFFSET	-028
DE8			E-W CORNER	-032 ~ 000 ~ +031	OFFSET	000
DF7	16:9 UNDER SCAN	50Hz	E-W PARABOLA	-064 ~ 000 ~ +063	OFFSET	014
DF8			E-W CORNER	-032 ~ 000 ~ +031	OFFSET	000
DG7	16:9 UNDER SCAN	60Hz	E-W PARABOLA	-064 ~ 000 ~ +063	OFFSET	014
DG8			E-W CORNER	-032 ~ 000 ~ +031	OFFSET	000



**CONTROL BLOCK**

Item	Contents	Variable Range	Attribute	Initial Value
C01	DESTINATION 0 : FOR JAPN (9300) 1 : FOR EUROPE / US (6500)	000 ~ 001	FIXED	001
C02	BRIGHT POINT	UPPER	FIXED	016
C03		LOWER	FIXED	026
C04	CONTRAST POINT	UPPER	FIXED	016
C05		LOWER	FIXED	026
C06	CHROMA POINT	UPPER	FIXED	040
C07		LOWER	FIXED	040
C08	PHASE POINT	UPPER	FIXED	040
C09		LOWER	FIXED	040
C10	OSD HORIZONTAL POSITION	000 ~ 010	FIXED	000
C11	OSD VERTICAL FREQUENCY 50Hz	000 ~ 010	FIXED	004
C12	OSD VERTICAL FREQUENCY 60Hz	000 ~ 010	FIXED	002
C13	HORIZONTAL CENTER (RGB)	-128 ~ 000 ~ +127	OFFSET	007
C14	HORIZONTAL CENTER (COMPONENT)	-128 ~ 000 ~ +127	OFFSET	002
C15	BRIGHT SERVICE	000 ~ 127	FIXED	000
C16	SHARPNESS CENTER	000 ~ 127	FIXED	024
C17	HVT H	000 ~ 007	FIXED	004
C18	HVT V	000 ~ 007	FIXED	003
C19	HVT H (UNDER SCAN)	000 ~ 007	FIXED	004
C20	HVT V (UNDER SCAN)	000 ~ 007	FIXED	003
C21	V-SS.CR	000 ~ 015	FIXED	005
C22	TRAPEZOID	000 ~ 127	FIXED	063
C23	HOUR METER	001 ~ 650	MEASURED	001
C24	RUSH DELAY	000 ~ 255	FIXED	032
C25	DEGAUSS DELAY TIME	000 ~ 255	FIXED	005
C26 ~C33	SLOT IDENTIFY	000 ~ 255	FIXED	000
C27	SLOT IDENTIFY	000 ~ 255	FIXED	006

## ADJUSTMENT

Item	Test equipment	Test points	Adjustment locations	Adjustment procedure
Checking of the B1 power supply	DC Voltmeter	TP-91(B1) : (S1 ① pin)  TP-E(GND) : (S1 ⑤ pin) [MAIN PWB]	B1 ADJUST VR [MAIN PWB]  SCREEN VR [Lower knob : in FBT]	<ol style="list-style-type: none"> <li>Set the power supply voltage to <b>AC230V±5V</b> (TM-H1700G/E) <b>AC120V±5V</b> (TM-H1700G/U)</li> <li>Select WHITE BALANCE BLOCK mode from &lt;BLOCK SELECT&gt; screen.</li> <li>Select CUTOFF adjustment mode (Low light mode).</li> <li>Press "SERV" switch to display the horizontal line.</li> <li>Adjust the SCREEN VR to disappear the horizontal line.</li> <li>Check the B1 voltage as <b>53V±0.2V</b>.</li> <li>Readjust the SCREEN VR to appear the horizontal line faintly, and cancel the horizontal line to press the "SERV" switch.</li> </ol>
Checking of the High voltage	High voltage meter	CRT Anode	SCREEN VR [Lower knob : in FBT]	<ol style="list-style-type: none"> <li>Set the power supply voltage to <b>AC230V±5V</b> (TM-H1700G/E) <b>AC120V±5V</b> (TM-H1700G/U).</li> <li>Select WHITE BALANCE BLOCK mode from &lt;BLOCK SELECT&gt; screen.</li> <li>Select CUTOFF adjustment mode (Low light mode).</li> <li>Press "SERV" switch to display the horizontal line.</li> <li>Adjust the SCREEN VR to disappear the horizontal line.</li> <li>Connect the high voltage meter to the CRT anode and check it as <b>25.0~27.0kV</b>.</li> <li>Readjust the SCREEN VR to appear the horizontal line faintly, and cancel the horizontal line to press the "SERV" switch.</li> </ol>
Focus adjustment	Signal generator (Resolution pattern)		FOCUS VR1 FOCUS VR2 [Upper knob : in FBT]	<ol style="list-style-type: none"> <li>Input the resolution pattern signal.</li> <li>Adjust the Focus VR1 and VR2 for optimum focus where moire is not apparent.</li> <li>Darken the picture and adjust the focus by turning counter-clockwise from the position where focus is poor.</li> <li>Alternately repeat the above steps to obtain the optimum position.</li> </ol>

- Must be input the composite video signal for adjusting the white balance.
- Set the aspect ratio to 4:3.
- There are no requirement for adjustment in the under scan mode and RGB / component signal mode.

Item	Test equipment	Test points	Adjustment locations	Adjustment procedure
White Balance (Low light) adjustment	Signal generator (Monoscope pattern)		<b>SCREEN VR</b> [Lower knob : in FBT]  <b>W01 R CUTOFF</b> <b>W02 G CUTOFF</b> <b>W03 B CUTOFF</b> <b>[SERVICE MENU]</b>	<ul style="list-style-type: none"> <li>● Under the condition that B1 voltage adjustment has been finished.</li> </ul> <ol style="list-style-type: none"> <li>1. Input the monoscope pattern signal.</li> <li>2. Select the WHITE BALANCE BLOCK mode from &lt;BLOCK SELECT&gt; screen.</li> <li>3. Confirm the initial setting value of W01, W02, W03 in the SERVICE MENU are 50.</li> <li>4. Select the CUTOFF adjustment mode.</li> <li>5. Press "SERV" switch to display the single horizontal line. Carefully adjust the SCREEN VR to horizontal line appears faintly, not to shine much.</li> <li>6. Gradually turn the SCREEN VR from the left to the right direction to bring one of the red, green and blue colours faintly visible.</li> <li>7. Then select the CUTOFF switch (R, G or B) that colour except for appears first, and adjusting 2 colours CUTOFF values by pressing the +key, and make horizontal line visible white.</li> <li>8. Readjust the SCREEN VR to appear the horizontal line faintly, and cancel the horizontal line to press the "SERV" switch.</li> </ol>
White Balance (High light) 6500K adjustment	Signal generator (Monoscope pattern)  Colour temperature meter or Colour Analyser		<b>W04 R DRIVE</b> <b>W05 B DRIVE</b> <b>[SERVICE MENU]</b>	<ul style="list-style-type: none"> <li>● Under the condition that Low light adjustment has been correctly finished.</li> </ul> <ol style="list-style-type: none"> <li>1. Input the monoscope pattern signal.</li> <li>2. Select the WHITE BALANCE BLOCK mode from &lt;BLOCK SELECT&gt; screen.</li> <li>3. Select the 6500 DRIVE adjustment mode (High light 6500 mode).</li> <li>4. Apply the sensor of the colour temperature meter to the CRT surface, portion of the 100% white, adjust the W04 (R DRIVE) or W05 (B DRIVE) to setting 6500K (x=0.313, y=0.329).</li> <li>5. Exit the SERVICE MENU by pressing the "EXIT" key.</li> <li>6. Check the white balance tracking is finest when CONTRAST and BRIGHT are up and down.</li> </ol>

Item	Test equipment	Test points	Adjustment locations	Adjustment procedure
<p><b>White Balance (High light) 9300K adjustment</b></p>	<p>Signal generator (Monoscope pattern)  Colour temperature meter or Colour Analyser</p>		<p><b>W06 R DRIVE W07 B DRIVE [SERVICE MENU]</b></p>	<ul style="list-style-type: none"> <li>Under the condition that Low light adjustment has been correctly finished.</li> </ul> <ol style="list-style-type: none"> <li>Input the monoscope pattern signal.</li> <li>Select the WHITE BALANCE BLOCK mode from &lt;BLOCK SELECT&gt; screen.</li> <li>Select the 9300 DRIVE adjustment mode (High light 9300 mode).</li> <li>Apply the sensor of the colour temperature meter to the CRT surface, portion of the 100% white, adjust the W06 (R DRIVE) or W07 (B DRIVE) to setting 6500K (x=0.283, y=0.297).</li> <li>Exit the SERVICE MENU by pressing the "EXIT" key.</li> <li>Check the white balance tracking is finest when CONTRAST and BRIGHT are up and down.</li> </ol>
<p><b>Bright adjustment</b></p>	<p>Signal generator (Sprit colour bar)</p>		<p><b>S01 (BRIGHT) [SERVICE MENU]</b></p>	<ul style="list-style-type: none"> <li>Under the condition that Low light adjustment has been correctly finished.</li> </ul> <ol style="list-style-type: none"> <li>Input a sprit colour bar signal.</li> <li>Select the SIGNAL BLOCK mode from &lt;BLOCK SELECT&gt; screen.</li> <li>Select the S01 item.</li> <li>Adjust the S01 to where the sprit colour bar 0% black component faintly brightens.</li> <li>Check it to on and off the screen display by turning the "DISP" switch.</li> </ol>
<p><b>Contrast adjustment</b></p>	<p>Signal generator (Full colour bar) Oscillo-scope</p>	<p><b>TP-47G TP-E( ↘ ) [CRT SOCKET PWB]</b></p>	<p><b>S02 (CONTRAST) [SERVICE MENU]</b></p>	<ol style="list-style-type: none"> <li>Input the full colour bar signal. (75 / 0 / 75 / 0 set-up level signal)</li> <li>Connect the oscillo-scope probe to TP-47G and TP-E( ↘ ).</li> <li>Select the SIGNAL BLOCK mode from &lt;BLOCK SELECT&gt; screen.</li> <li>Select the S02 item.</li> <li>Adjust the S02 to become the voltage different between 75% white and 0% black to <b>40V±2Vp-p</b> as shown in figure.</li> </ol>

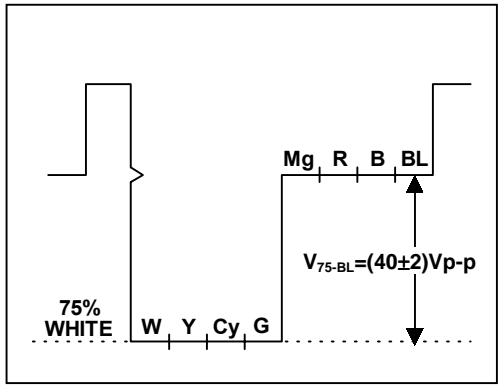

Item	Test equipment	Test points	Adjustment locations	Adjustment procedure
<p><b>PAL CHROMA Saturation adjustment</b></p>	<p>Signal generator (Full colour bar)  Oscillo-scope</p>	<p>TP-47B TP-E(↗) [CRT SOCKET PWB]</p>	<p>S03(PAL CHROMA) [SERVICE MENU]</p>	<ol style="list-style-type: none"> <li>1. Input a PAL full colour bar signal.</li> <li>2. Connect the oscillo-scope probe to TP-47B and TP-E(↗).</li> <li>3. Select the SIGNAL BLOCK mode from &lt;BLOCK SELECT&gt; screen.</li> <li>4. Select the S03 item.</li> <li>5. Adjust the S03 to become the voltage different between 75% white and blue to <b>0V±2Vp-p</b> as shown in figure.</li> </ol>
<p><b>NTSC 3.58 CHROMA Saturation adjustment</b></p>	<p>Signal generator (Full colour bar)  Oscillo-scope</p>	<p>TP-47B TP-E(↗) [CRT SOCKET PWB]</p>	<p>S04 (NTSC CHROMA) [SERVICE MENU]</p>	<ol style="list-style-type: none"> <li>1. Input a NTSC 3.58 full colour bar signal.</li> <li>2. Connect the oscillo-scope probe to TP-47B and TP-E(↗).</li> <li>3. Select the SIGNAL BLOCK mode from &lt;BLOCK SELECT&gt; screen.</li> <li>4. Select the S04 item.</li> <li>5. Adjust the S04 to become the voltage different between 75% white and blue to <b>0V±2Vp-p</b> as shown in figure.</li> </ol>

Item	Test equipment	Test points	Adjustment locations	Adjustment procedure
<p><b>NTSC 3.58 PHASE adjustment</b></p>	<p>Signal generator (Full colour bar)  Oscillo-scope</p>	<p>TP-47B TP-E(↗) [CRT SOCKET PWB]</p>	<p><b>S05 (NTSC PHASE) [SERVICE MENU]</b></p>	<ol style="list-style-type: none"> <li>1. Input a NTSC 3.58 full colour bar signal.</li> <li>2. Connect the oscillo-scope probe to TP-47B and TP-E(↗).</li> <li>3. Select the SIGNAL BLOCK from SERVICE MENU.</li> <li>4. Select the S05 item.</li> <li>5. Adjust the S05 to become the voltage different between 75% white and magenta to <math>0V \pm 2V_{p-p}</math> as shown in figure.</li> </ol>

## DEFLECTION CIRCUIT ADJUSTMENT

There are 2 kind of adjustment for the DEFLECTION circuit, PAL and NTSC. The adjustment using PAL signal is as the standard of all DEFLECTION adjustment. The “#” mark in the table given below expresses the number of each adjustment item. The screen aspect ratio 4 : 3 at 50Hz (PAL) is regarded as the reference value for all adjustments. The other values obtained in the adjustments using other signals become the offset values as opposed to the reference values.

**Therefore, the adjustments must always be carried out in order of PAL and NTSC.** When it does not adjust in this turn, and when operation which is different by the middle is carried out, it is necessary to readjust from the beginning.

MODE			DISPLAY
ASPECT RATIO	SCAN SIZE	VERTICAL FREQUENCY	
4:3	NORMAL SCAN	50Hz(PAL)	D0#
		60Hz(NTSC)	DA#
16:9	NORMAL SCAN	50Hz(PAL)	DB#
		60Hz(NTSC)	DC#
4:3	UNDER SCAN	50Hz(PAL)	DD#
		60Hz(NTSC)	DE#
16:9	UNDER SCAN	50Hz(PAL)	DB#, DD#, DF#
		60Hz(NTSC)	DC#, DE#, DG#

Although the procedure is described about the adjustment at the time of inputting a PAL signal into below, please perform adjustment which inputs an NTSC signal continuously.

However, about each adjustment item of "Vertical center", "Vertical linearity", "16:9 Vertical size" and "Horizontal size and center at the time of under scan mode", it considers as the adjustment only to a PAL signal, and adjustment with an NTSC signal is not required.

Item	Test equipment	Test points	Adjustment locations	Adjustment procedure
<b>H. Center</b> <b>H. Size</b> <b>Adjustment</b>	Signal generator (Crosshatch pattern)		D01 (H. CENTER) D02 (H. SIZE) [SERVICE MENU]	<ol style="list-style-type: none"> <li>1. Input a crosshatch pattern signal.</li> <li>2. Select DEFLECTION BLOCK mode from &lt;BLOCK SELECT&gt; screen.</li> <li>3. Select D01 item.</li> <li>4. Adjust D01 to align the picture center with the CRT center.</li> <li>5. Adjust D02 to set horizontal size to <b>95%</b>.</li> <li>6. Repeat above step 4 and 5 to adjust correctly.</li> </ol>
<b>Side pincushion</b> <b>Adjustment</b>	Signal generator (Crosshatch pattern)		D07 (E-W PARABOLA) D08 (E-W CORNER) [SERVICE MENU]	<ol style="list-style-type: none"> <li>7. Confirm the side pincushion of the four corners in the screen.</li> <li>8. If not optimum, adjust the D07 and D08 to become correctly.</li> </ol>

Item	Test equipment	Test points	Adjustment locations	Adjustment procedure
<p><b>V. Center Adjustment</b></p> <p>Only for PAL signal adjustment</p>	<p>Signal generator (Circle pattern)</p>		<p><b>D03 (V. CENTER)</b> [SERVICE MENU]</p>	<p>9. Input the PAL circle pattern signal. 10. Adjust D03 to agree with CRT center and signal center of vertical direction.</p>
<p><b>V. Lin Adjustment</b></p> <p>Only for PAL signal adjustment</p>	<p>Signal generator (Circle pattern)</p>		<p><b>D04 (V. SIZE)</b> <b>D05 (V. LIN)</b> <b>D06 (V. S. COR)</b> [SERVICE MENU]</p>	<p>11. Input the PAL circle pattern signal. 12. Select the D04 to adjust the vertical size become 100%. 13. Select the D05 and reference to the below figure, adjust it to become correctly about vertical size and vertical linearity.  14. Select D06 and adjust it to the circle pattern becomes the true circle at top and bottom of the screen.</p>

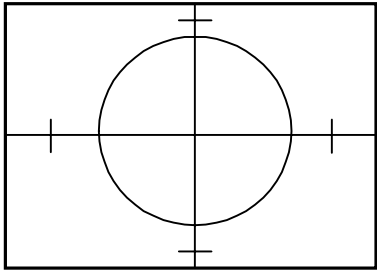

Top extension

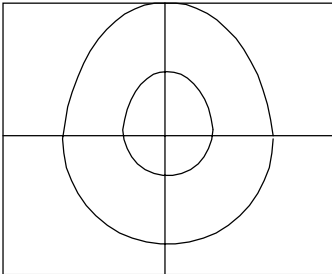

Correct adjustment

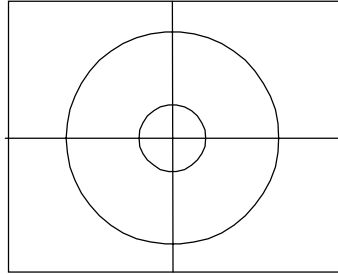

Bottom extension

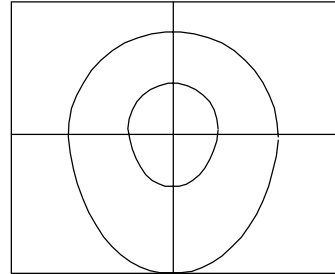

Vertical extension

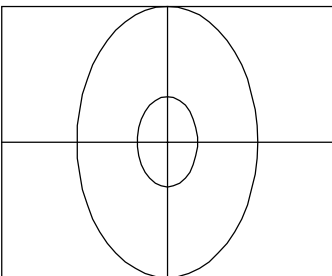

Correct adjustment

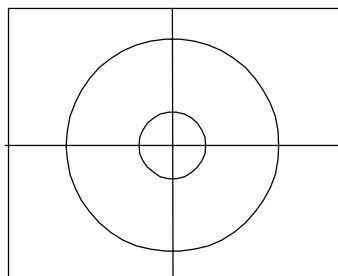

Horizontal extension

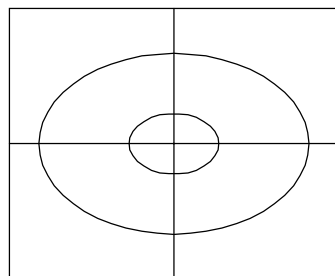



Item	Test equipment	Test points	Adjustment locations	Adjustment procedure		
<p><b>V. Size Adjustment</b></p>	<p>Signal generator (Crosshatch pattern)</p>		<p><b>D04 (V. SIZE)</b> [SERVICE MENU]</p>	<p>15. Input the crosshatch signal. 16. Select D04 item, and adjust it to become the vertical scan size to <b>95%</b>.</p>		
<p><b>16:9 V. Size Adjustment</b></p> <div style="border: 1px solid black; padding: 2px; width: fit-content;"> <p>Only for PAL signal adjustment</p> </div>	<p>Signal generator (Circle pattern)</p>		<p><b>DB04 (V. SIZE)</b> [SERVICE MENU]</p>	<p>17. Input the PAL circle pattern signal. 18. Switch the aspect ratio to the 16:9 mode. 19. Adjust the DB04 to the vertical size become the value given below.</p> <div style="border: 1px solid black; padding: 5px; margin: 10px auto; width: 80%; text-align: center;"> <table style="width: 100%; border-collapse: collapse;"> <tr> <td style="border: 1px solid black; padding: 5px; width: 50%;"><b>Vertical size</b></td> <td style="border: 1px solid black; padding: 5px; width: 50%;"><b>196±4mm</b></td> </tr> </table> </div>	<b>Vertical size</b>	<b>196±4mm</b>
<b>Vertical size</b>	<b>196±4mm</b>					
<p><b>16:9 Side pincushion Adjustment</b></p>	<p>Signal generator</p>		<p><b>DB07 (E-W PARABOLA)</b>  <b>DB08 (E-W CORNER)</b> [SERVICE MENU]</p>	<p>20. Confirm the side pincushion of the four corners in the screen. 21. If not optimum, adjust the DB07 and DB08 to become correctly.</p>		

Item	Test equipment	Test points	Adjustment locations	Adjustment procedure		
<p>Under scan Horizontal Size</p> <p>Horizontal center</p> <p>Adjustment</p> <div data-bbox="76 600 228 678" style="border: 1px solid black; padding: 2px;">                     Only for PAL signal adjustment                 </div>	<p>Signal generator (Circle pattern)</p>		<p>DD01 (H. CENTER) DD02 (H. SIZE) [SERVICE MENU]</p>	<p>22. Input the PAL circle pattern signal. 23. Select the under scan mode. 24. Select the DD01 and adjust it to the left and right blanking width become equal. 25. Select the DD02 and adjust it to the left and right blanking width become the value given below.</p> <div data-bbox="911 837 1394 965" style="border: 1px solid black; padding: 5px; margin-top: 20px;"> <table style="width: 100%; border-collapse: collapse;"> <tr> <td style="border: 1px solid black; padding: 2px; text-align: center;"><b>Horizontal Blanking Width (one side of screen)</b></td> <td style="border: 1px solid black; padding: 2px; text-align: center;"><b>6~9mm</b></td> </tr> </table> </div>	<b>Horizontal Blanking Width (one side of screen)</b>	<b>6~9mm</b>
<b>Horizontal Blanking Width (one side of screen)</b>	<b>6~9mm</b>					
<p>Under scan Horizontal Size</p> <p>Horizontal center</p> <p>Adjustment</p>	<p>Signal generator (Crosshatch pattern)</p>		<p>DD07 (E-W PARABOLA) DD08 (E-W CORNER) [SERVICE MENU]</p>	<p>26. Confirm the side pincushion of the four corners in the screen. 27. If not optimum, adjust the DD07 and DD08 to become correctly. 28. If the warps are happened by adjust the side pincushion, readjust the above-mentioned DD01 and DD02.</p>		
<p>16:9 Under scan Side pincushion</p> <p>Adjustment</p>	<p>Signal generator (Crosshatch pattern)</p>		<p>DF07 (E-W PARABOLA) DF08 (E-W CORNER) [SERVICE MENU]</p>	<p>29. Switch the aspect ratio to the 16:9 mode. 30. Confirm the side pincushion of the four corners in the screen. 31. If not optimum, adjust the DF07 and DF08 to become correctly. 32. If the warps are happened by adjust the side pincushion, readjust the above-mentioned DD01 and DD02. 33. Turn the scan size to the normal.</p>		

# PURITY, CONVERGENCE ADJUSTMENT

## PURITY ADJUSTMENT

1. Demagnetize CRT with the demagnetizer.
2. Loosen the retainer screw of the deflection yoke.
3. Remove the wedges.
4. Input a green raster signal from the signal generator, and turn the screen to green raster.
5. Move the deflection yoke backward.
6. Bring the long lug of the purity magnets on the short lug and position them horizontally. (Fig.2)
7. Adjust the gap between two lugs so that the GREEN RASTER will come into the center of the screen. (Fig.3)
8. Move the deflection yoke forward, and fix the position of the deflection yoke so that the whole screen will become green.
9. Insert the wedge to the top side of the deflection yoke so that it will not move.
10. Input a crosshatch signal.
11. Verify that the screen is horizontal.
12. Input red and blue raster signals, and make sure that purity is properly adjusted.

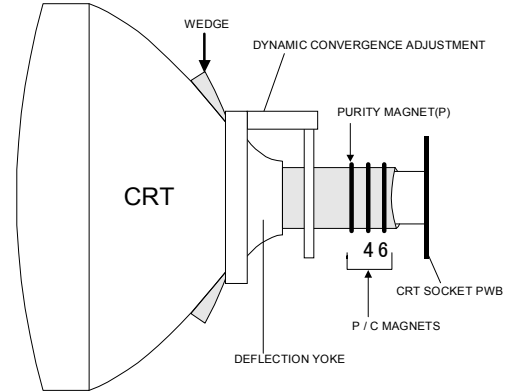

### P/C MAGNETS

- P : PURITY MAGNET
- 4 : 4 POLES (convergence magnets)
- 6 : 6 POLES (convergence magnets)

Fig.1

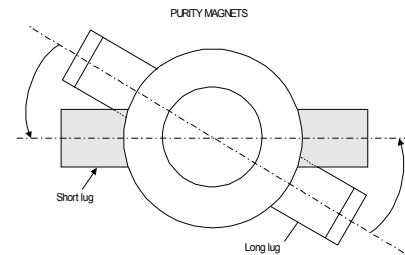

Bring the long lug over the short lug and position them horizontally.

Fig.2

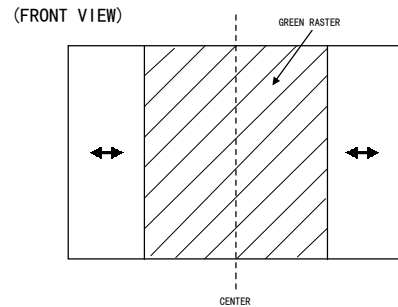

Fig.3

**STATIC CONVERGENCE ADJUSTMENT**

1. Input a crosshatch signal.
  2. Using 4-pole convergence magnets, overlap the red and blue lines in the center of the screen (Fig.1) and turn them to magenta (red/blue).
  3. Using 6-pole convergence magnets, overlap the magenta (red/blue) and green lines in the center of the screen and turn them to white.
  4. Repeat 2 and 3 above, and make best convergence.
- After adjustment, fix the wedge at the original position.  
Fasten the retainer screw of the deflection yoke.  
Fix the 6 magnets with glue.

**DYNAMIC (periphery) CONVERGENCE ADJUSTMENT**

After adjusting purity & static convergence.

1. Move the deflection yoke up and down to adjust the pin cushion distortion in the screen top and bottom. (See Fig. 2)
2. Move the deflection yoke left to right to overlap the lines in the periphery, and match the Yv(VR1). (As shown in Fig. 4)
3. Using the VR1 on the deflection yoke, match the Y<sub>H</sub> (CROSS). (See Fig. 3 and 6)
4. Using the VR2 on the deflection yoke, match the Y<sub>H</sub> (BOW). (See Fig. 3 and 6)
5. Repeat the steps 1 and 4 and obtain an optimum convergence.
6. Differential(XV) coil ADJUSTMENT.  
In case where the horizontal lines of red and blue around the center of both sides of the picture as shown in Fig. 5, adjust the X<sub>v</sub> difference by using the differential coil(XV coil) on the top of the deflection yoke (Fig. 6) so as to minimize the X<sub>v</sub> difference.

**DEF YOKE PWB (Within DY)**

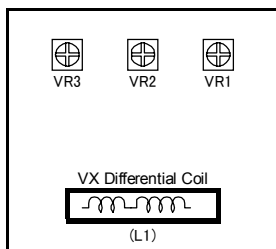

Fig.6

(FRONT VIEW)

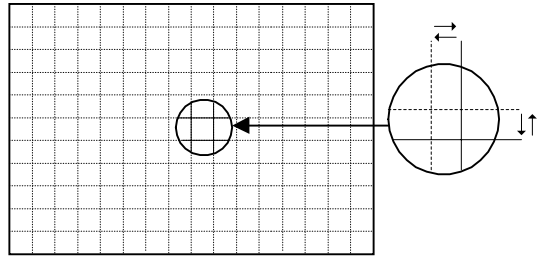

Fig. 1

(FRONT VIEW)

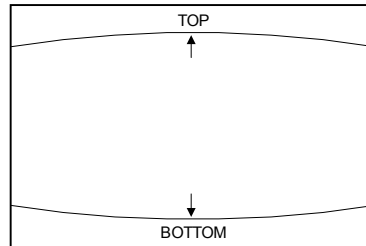

Fig. 2

(FRONT VIEW)

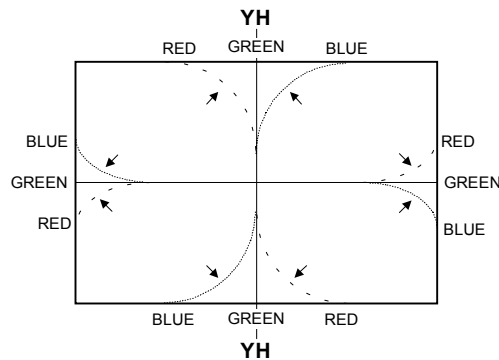

Fig. 3

(FRONT VIEW)

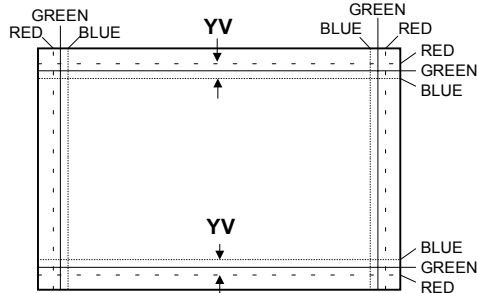

Fig. 4

(FRONT VIEW)

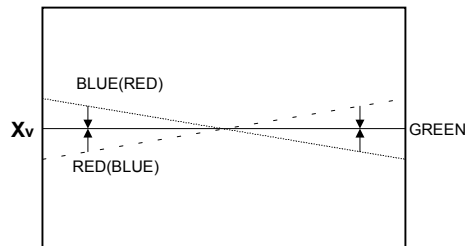

Fig. 5

## REPLACE OF THE CHIP COMPONENT

### ■ CAUTIONS

1. Avoid heating for more than 3 seconds.
2. Do not rub the electrodes and the resist parts of the pattern.
3. When removing a chip part, melt the solder adequately.
4. Do not reuse a chip part after removing it.

### ■ SOLDERING IRON

1. Use a high insulation soldering iron with a thin pointed end of it.
2. A 30w soldering iron is recommended for easily removing parts.

### ■ REPLACEMENT STEPS

#### 1. How to remove Chip parts

##### ◆ Resistors, capacitors, etc.

- (1) As shown in the figure, push the part with tweezers and alternately melt the solder at each end.

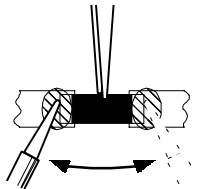

- (2) Shift with tweezers and remove the chip part.

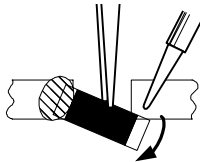

##### ◆ Transistors, diodes, variable resistors, etc.

- (1) Apply extra solder to each lead.

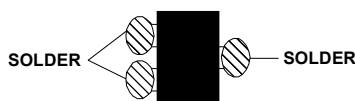

- (2) As shown in the figure, push the part with tweezers and alternately melt the solder at each lead. Shift and remove the chip part.

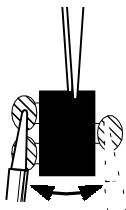

Note : After removing the part, remove remaining solder from the pattern.

#### 2. How to install Chip parts

##### ◆ Resistors, capacitors, etc.

- (1) Apply solder to the pattern as indicated in the figure.

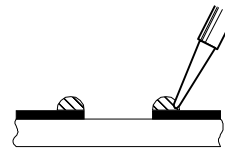

- (2) Grasp the chip part with tweezers and place it on the solder. Then heat and melt the solder at both ends of the chip part.

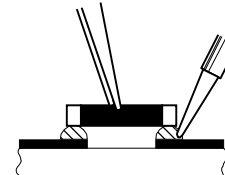

##### ◆ Transistors, diodes, variable resistors, etc.

- (1) Apply solder to the pattern as indicated in the figure.
- (2) Grasp the chip part with tweezers and place it on the solder.
- (3) First solder lead **A** as indicated in the figure.

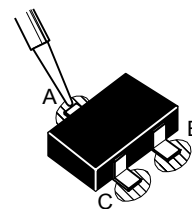

- (4) Then solder leads **B** and **C**.

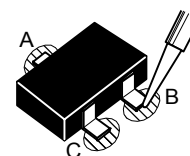

# SELF DIAGNOSIS FUNCTION

## 1. OUTLINE

This model includes a SELF-DIAGNOSIS FUNCTION that checks the circuit operating status and in event of malfunction, displays and stores the data in a memory. The data are stored in an I<sup>2</sup>C memory.  
 Fault detection starts with the I<sup>2</sup>C bus and is performed according to the input states of the control lines connected to the MAIN CPU.

## 2. USAGE

### SELF DIAGNOSIS FUNCTION mode entry

- (1) While press the **MENU** key and **CONTRAST/BRIGHT** key simultaneously, and push the power switch on the front panel to turn on.
- (2) Then displays the SELF-DIAGNOSIS FUNCTION screen. The screen indicates as shown in the table and the SELF-DIAGNOSIS FUNCTION mode is entered. If in event a malfunction at RASTER not display, at this time POWER LED flashes.

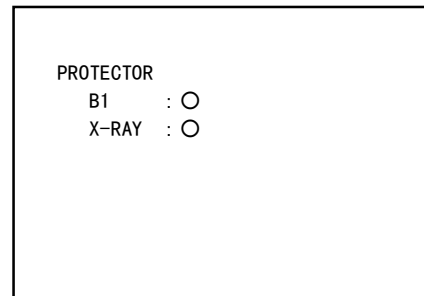

CAUSE	LED FLASHING CYCLE
X-RAY PROTECTOR	Quickly (0.1 sec on / 0.1 sec off cycles)
OVER CURRENT PROTECTOR	Slowly (1.0 sec on / 1.0 sec off cycles)

### SELF DIAGNOSIS FUNCTION mode release

Turn the power switch to off or disconnect the power plug from AC outlet. In this way, not to clear the error counts.

### Reset the error count

- (1) While press the **MENU** key and **CHROMA/PHASE** key simultaneously, and push the MAIN POWER switch on.
- (2) Then displays the screen as shown right. Press the "+" key. Then clear the error count of the each item.

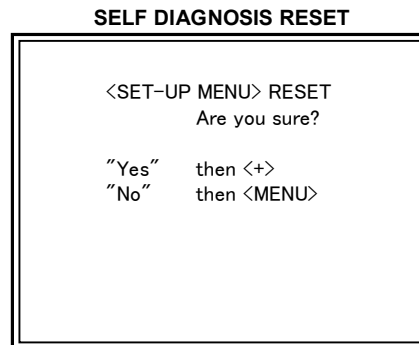

### Fault history

The fault history counts up to a maximum of 9 times for each item. If the number of times exceeds 9, the display remains at 9. The fault history remains stored in the memory until deleted.

## 3. CONTENTS

DISPLAY	DETECT CONTENTS
B1	Power and deflection circuit
X-RAY	X-Ray protection circuit action